

Notification Date: 7AM EST 10/20/2023

New Tower ("NT") Submission Packet

See instructions for
public burden estimates

File Number: 0010740923

General Information

1) (Select only one) (NE) NE – New UA – Update of Application WD – Withdrawal of Application	
2) If this application is for an Update or Withdrawal, enter the file number of the pending application currently on file.	File Number:

Applicant Information

3) FCC Registration Number (FRN): 0029376670
4) Name: Boldyn Networks Infrastructure US LLC

Contact Name

5) First Name: Tammi	6) MI:	7) Last Name: Grant	8) Suffix:
9) Title: Director, Network Real Estate			

Contact Information

10) P.O. Box:	And /Or	11) Street Address: 1400 Broadway, 17th Floor	
12) City: New York		13) State: NY	14) Zip Code: 10018
15) Telephone Number: (212)931-9020		16) Fax Number:	
17) E-mail Address: tammi.grant@boldyn.com			

Consultant Information

18) FCC Registration Number (FRN): 0016385759
19) Name: EnviroBusiness Inc. d/b/a EBI Consulting (EBI 6123006709)

Principal Investigator

20) First Name: Chris	21) MI:	22) Last Name: Robinson	23) Suffix:
24) Title: Architectural Historian II			

Principal Investigator Contact Information

25) P.O. Box:	And /Or	26) Street Address: 21 B Street	
27) City: Burlington		28) State: MA	29) Zip Code: 01803
30) Telephone Number: (978)877-3493		31) Fax Number:	
32) E-mail Address: crobinson@ebiconsulting.com			

Professional Qualification

33) Does the Principal Investigator satisfy the Secretary of the Interior's Professional Qualification Standards?	(<input checked="" type="checkbox"/>) <u>Y</u> es () <u>N</u> o
34) Areas of Professional Qualification:	
() Archaeologist	
(<input checked="" type="checkbox"/>) Architectural Historian	
() Historian	
() Architect	
() Other (Specify) _____	

Additional Staff

35) Are there other staff involved who meet the Professional Qualification Standards of the Secretary of the Interior?	(<input checked="" type="checkbox"/>) <u>Y</u> es () <u>N</u> o
--	--

If "YES," complete the following:

36) First Name: Kelsey	37) MI:	38) Last Name: Lamkin	39) Suffix:
40) Title:			
41) Areas of Professional Qualification:			
() Archaeologist			
() Architectural Historian			
(<input checked="" type="checkbox"/>) Historian			
() Architect			
() Other (Specify) _____			

36) First Name: Alexander	37) MI:	38) Last Name: O'Gorman	39) Suffix:
40) Title:			
41) Areas of Professional Qualification:			
() Archaeologist			
(<input checked="" type="checkbox"/>) Architectural Historian			
() Historian			
() Architect			
() Other (Specify) _____			

36) First Name: Tory	37) MI:	38) Last Name: Harding	39) Suffix:
40) Title:			
41) Areas of Professional Qualification:			
<input checked="" type="checkbox"/> Archaeologist <input type="checkbox"/> Architectural Historian <input type="checkbox"/> Historian <input type="checkbox"/> Architect <input type="checkbox"/> Other (Specify) _____			

36) First Name: Stefanie	37) MI:	38) Last Name: Turner	39) Suffix:
40) Title:			
41) Areas of Professional Qualification:			
<input type="checkbox"/> Archaeologist <input checked="" type="checkbox"/> Architectural Historian <input type="checkbox"/> Historian <input type="checkbox"/> Architect <input type="checkbox"/> Other (Specify) _____			

36) First Name: Chris	37) MI:	38) Last Name: Grant	39) Suffix:
40) Title:			
41) Areas of Professional Qualification:			
<input checked="" type="checkbox"/> Archaeologist <input type="checkbox"/> Architectural Historian <input type="checkbox"/> Historian <input type="checkbox"/> Architect <input type="checkbox"/> Other (Specify) _____			

Site Information

Tower Construction Notification System

1) TCNS Notification Number: **272298**

Site Information

2) Positive Train Control Filing Subject to Expedited Treatment Under Program Comment: () Yes (**X**) No

3) Site Name: **MN-07-120527_A**

4) Site Address: **741 Columbus Avenue**

5) Detailed Description of Project:

Proposed telecommunications facility resulting in minimal ground disturbance. Please see Attachment 4 of this filing for project design details. 6123006709

6) City: **New York**

7) State: **NY**

8) Zip Code: **10025**

9) County/Borough/Parish: **NEW YORK**

10) Nearest Crossroads: **Columbus Ave and W 97th St**

11) NAD 83 Latitude (DD-MM-SS.S): **40-47-36.2**

(**X**) N or () S

12) NAD 83 Longitude (DD-MM-SS.S): **073-58-01.2**

() E or (**X**) W

Tower Information

13) Tower height above ground level (include top-mounted attachments such as lightning rods): **9.8** () Feet (**X**) Meters

14) Tower Type (Select One):

() Guyed lattice tower

() Self-supporting lattice

(**X**) Monopole

() Other (Describe):

Project Status

15) Current Project Status (Select One):

(**X**) Construction has not yet commenced

() Construction has commenced, but is not completed

Construction commenced on: _____

() Construction has been completed

Construction commenced on: _____

Construction completed on: _____

Determination of Effect

14) Direct Effects (Select One):

- No Historic Properties in Area of Potential Effects (APE)
- No Effect on Historic Properties in APE
- No Adverse Effect on Historic Properties in APE
- Adverse Effect on one or more Historic Properties in APE

15) Visual Effects (Select One):

- No Historic Properties in Area of Potential Effects (APE)
- No Effect on Historic Properties in APE
- No Adverse Effect on Historic Properties in APE
- Adverse Effect on one or more Historic Properties in APE

Historic Properties

Properties Identified

1) Have any historic properties been identified within the APEs for direct and visual effect?	(<input checked="" type="checkbox"/>) <u>Y</u> es () <u>N</u> o
2) Has the identification process located archaeological materials that would be directly affected, or sites that are of cultural or religious significance to Tribes/NHOs?	() <u>Y</u> es (<input checked="" type="checkbox"/>) <u>N</u> o
3) Are there more than 10 historic properties within the APEs for direct and visual effect? If "Yes", you are required to attach a Cultural Resources Report in lieu of adding the Historic Property below.	() <u>Y</u> es (<input checked="" type="checkbox"/>) <u>N</u> o

Historic Property

4) Property Name: Upper West Side / Central Park West Historic District
5) SHPO Site Number: LP-1647

Property Address

6) Street Address: multiple		
7) City: New York	8) State: NY	9) Zip Code: 10025
10) County/Borough/Parish: NEW YORK		

Status & Eligibility

11) Is this property listed on the National Register? Source: _____	() <u>Y</u> es (<input checked="" type="checkbox"/>) <u>N</u> o
12) Is this property eligible for listing on the National Register? Source: <u>NY SHPO</u> _____	(<input checked="" type="checkbox"/>) <u>Y</u> es () <u>N</u> o
13) Is this property a National Historic Landmark?	() <u>Y</u> es (<input checked="" type="checkbox"/>) <u>N</u> o

14) Direct Effects (Select One): <input checked="" type="checkbox"/> No Effect on this Historic Property in APE <input type="checkbox"/> No Adverse Effect on this Historic Property in APE <input type="checkbox"/> Adverse Effect on this Historic Property in APE
15) Visual Effects (Select One): <input checked="" type="checkbox"/> No Effect on this Historic Property in APE <input type="checkbox"/> No Adverse Effect on this Historic Property in APE <input type="checkbox"/> Adverse Effect on this Historic Property in APE

Local Government Involvement

Local Government Agency

1) FCC Registration Number (FRN):
2) Name: New York City Landmarks Preservation Commission

Contact Name

3) First Name: Gina	4) MI:	5) Last Name: Santucci	6) Suffix:
7) Title: Environmental Review Coordinator			

Contact Information

8) P.O. Box:	And /Or	9) Street Address: 1 Centre Street, 9th Floor North	
10) City: New York		11) State: NY	12) Zip Code: 10007
13) Telephone Number: (000)000-0000		14) Fax Number:	
15) E-mail Address: GSantucci@lpc.nyc.gov			
16) Preferred means of communication: (<input checked="" type="checkbox"/>) E-mail (<input type="checkbox"/>) Letter (<input type="checkbox"/>) Both			

Dates & Response

17) Date Contacted 10/03/2023	18) Date Replied _____
(<input checked="" type="checkbox"/>) No Reply	
(<input type="checkbox"/>) Replied/No Interest	
(<input type="checkbox"/>) Replied/Have Interest	
(<input type="checkbox"/>) Replied/Other	

Additional Information

19) Information on local government's role or interest (optional):
--

Other Consulting Parties

Other Consulting Parties Contacted

1) Has any other agency been contacted and invited to become a consulting party?	(<input checked="" type="checkbox"/>) <u>Yes</u> () <u>No</u>
--	---

Consulting Party

2) FCC Registration Number (FRN):
3) Name: Historic Districts Council

Contact Name

4) First Name: Frampton	5) MI:	6) Last Name: Tolbert	7) Suffix:
8) Title:			

Contact Information

9) P.O. Box:	And /Or	10) Street Address: 232 East 11th Street		
11) City: New York		12) State: NY	13) Zip Code: 10003	
14) Telephone Number: (212)614-9107		15) Fax Number:		
16) E-mail Address: framptont@hdc.org				
17) Preferred means of communication: (<input checked="" type="checkbox"/>) E-mail () Letter () Both				

Dates & Response

18) Date Contacted 10/03/2023	19) Date Replied _____
(<input checked="" type="checkbox"/>) No Reply	
() Replied/No Interest	
() Replied/Have Interest	
() Replied/Other	

Additional Information

20) Information on other consulting parties' role or interest (optional):

Other Consulting Parties

Other Consulting Parties Contacted

1) Has any other agency been contacted and invited to become a consulting party?	(<input checked="" type="checkbox"/>) <u>Yes</u> (<input type="checkbox"/>) <u>No</u>
--	---

Consulting Party

2) FCC Registration Number (FRN):
3) Name: New York Landmark Conservancy

Contact Name

4) First Name: Andrea	5) MI:	6) Last Name: Goldwyn	7) Suffix:
8) Title:			

Contact Information

9) P.O. Box:	And /Or	10) Street Address: One Whitehall Street 21st Floor
11) City: New York	12) State: NY	13) Zip Code: 10004
14) Telephone Number: (212)995-5260	15) Fax Number:	
16) E-mail Address: andreagoldwyn@nylandmarks.org		
17) Preferred means of communication: (<input checked="" type="checkbox"/>) E-mail (<input type="checkbox"/>) Letter (<input type="checkbox"/>) Both		

Dates & Response

18) Date Contacted 10/03/2023	19) Date Replied _____
(<input checked="" type="checkbox"/>) No Reply (<input type="checkbox"/>) Replied/No Interest (<input type="checkbox"/>) Replied/Have Interest (<input type="checkbox"/>) Replied/Other	

Additional Information

20) Information on other consulting parties' role or interest (optional):

Other Consulting Parties

Other Consulting Parties Contacted

1) Has any other agency been contacted and invited to become a consulting party?	(<input checked="" type="checkbox"/>) <u>Yes</u> (<input type="checkbox"/>) <u>No</u>
--	---

Consulting Party

2) FCC Registration Number (FRN):
3) Name: Preservation League of New York State

Contact Name

4) First Name: Jana	5) MI:	6) Last Name: Rudler	7) Suffix:
8) Title:			

Contact Information

9) P.O. Box:	And /Or	10) Street Address: 44 Central Avenue
11) City: Albany	12) State: NY	13) Zip Code: 12206
14) Telephone Number: (585)314-9378	15) Fax Number:	
16) E-mail Address: jrudler@preservenys.org		
17) Preferred means of communication: (<input checked="" type="checkbox"/>) E-mail (<input type="checkbox"/>) Letter (<input type="checkbox"/>) Both		

Dates & Response

18) Date Contacted 10/03/2023	19) Date Replied _____
(<input checked="" type="checkbox"/>) No Reply (<input type="checkbox"/>) Replied/No Interest (<input type="checkbox"/>) Replied/Have Interest (<input type="checkbox"/>) Replied/Other	

Additional Information

20) Information on other consulting parties' role or interest (optional):

Other Consulting Parties

Other Consulting Parties Contacted

1) Has any other agency been contacted and invited to become a consulting party?	(<input checked="" type="checkbox"/>) <u>Yes</u> (<input type="checkbox"/>) <u>No</u>
--	---

Consulting Party

2) FCC Registration Number (FRN):
3) Name: Municipal Art Society

Contact Name

4) First Name: Elizabeth	5) MI:	6) Last Name: Goldstein	7) Suffix:
8) Title: President			

Contact Information

9) P.O. Box:	And /Or	10) Street Address: 488 Madison Avenue, Suite 1900
11) City: New York	12) State: NY	13) Zip Code: 10022
14) Telephone Number: (212)935-3960	15) Fax Number:	
16) E-mail Address: egoldstein@mas.org		
17) Preferred means of communication: (<input checked="" type="checkbox"/>) E-mail (<input type="checkbox"/>) Letter (<input type="checkbox"/>) Both		

Dates & Response

18) Date Contacted 10/03/2023	19) Date Replied _____
(<input checked="" type="checkbox"/>) No Reply (<input type="checkbox"/>) Replied/No Interest (<input type="checkbox"/>) Replied/Have Interest (<input type="checkbox"/>) Replied/Other	

Additional Information

20) Information on other consulting parties' role or interest (optional):

Other Consulting Parties

Other Consulting Parties Contacted

1) Has any other agency been contacted and invited to become a consulting party?	(<input checked="" type="checkbox"/>) Yes (<input type="checkbox"/>) No
--	---

Consulting Party

2) FCC Registration Number (FRN):
3) Name: Landmark West!

Contact Name

4) First Name: Sean	5) MI:	6) Last Name: Khorsandi	7) Suffix:
8) Title:			

Contact Information

9) P.O. Box:	And /Or	10) Street Address: 45 W 67th St #1		
11) City: New York		12) State: NY	13) Zip Code: 10023	
14) Telephone Number: (212)496-8110		15) Fax Number:		
16) E-mail Address: seankhorsandi@landmarkwest.org				
17) Preferred means of communication: (<input checked="" type="checkbox"/>) E-mail (<input type="checkbox"/>) Letter (<input type="checkbox"/>) Both				

Dates & Response

18) Date Contacted 10/03/2023	19) Date Replied _____
(<input checked="" type="checkbox"/>) No Reply	
(<input type="checkbox"/>) Replied/No Interest	
(<input type="checkbox"/>) Replied/Have Interest	
(<input type="checkbox"/>) Replied/Other	

Additional Information

20) Information on other consulting parties' role or interest (optional):

Designation of SHPO/THPO

1) Designate the Lead State Historic Preservation Officer (SHPO) or Tribal Historic Preservation Officer (THPO) based on the location of the tower.

SHPO/THPO

Name: **New York State Historic Preservation Office**

2) You may also designate up to three additional SHPOs/THPOs if the APEs include multiple states. If the APEs include other countries, enter the name of the National Historic Preservation Agency and any state and provincial Historic Preservation Agency.

SHPO/THPO Name: _____

SHPO/THPO Name: _____

SHPO/THPO Name: _____

Certification

I certify that all representations on this FCC Form 620 Submission Packet and the accompanying attachments are true, correct, and complete.

Party Authorized to Sign

First Name: **Chris**

MI:

Last Name: **Robinson**

Suffix:

Signature: **Chris Robinson**

Date: **10/19/2023**

FAILURE TO SIGN THIS APPLICATION MAY RESULT IN DISMISSAL OF THE APPLICATION AND FORFEITURE OF ANY FEES PAID.

WILLFUL FALSE STATEMENTS MADE ON THIS FORM OR ANY ATTACHMENTS ARE PUNISHABLE BY FINE AND/OR IMPRISONMENT (U.S. Code, Title 18, Section 1001) AND/OR REVOCATION OF ANY STATION LICENSE OR CONSTRUCTION PERMIT (U.S. Code, Title 47, Section 312(a)(1)), AND/OR FORFEITURE (U.S. Code, Title 47, Section 503).

Attachments :

Type	Description	Date Entered
Resumes/Vitae	Attachment 1	10/17/2023
Photographs	Attachment 2	10/17/2023
Map Documents	Attachment 3	10/17/2023
Additional Site Information	Attachment 4	10/17/2023
Area of Potential Effects	Attachment 5	10/17/2023
Tribal/NHO Involvement	Attachment 6	10/17/2023
Historic Properties for Direct Effects	Attachment 7	10/17/2023
Historic Properties for Visual Effects	Attachment 8	10/17/2023
Local Government Involvement	Attachment 9	10/17/2023
Public Involvement	Attachment 10	10/17/2023
State-Specific Forms	Attachment 11	10/17/2023

NT SUBMISSION PACKET -- FCC FORM 620

Approved by OMB
3060-1039
See instructions for
public burden estimates

Attachment I. Consultant Information

Provide a current copy of the résumé or curriculum vitae for the Principal Investigator and any researcher or other person who contributed to, reviewed, or provided significant input into the research, analysis, writing or conclusions presented in this filing.

The résumé for the Principal Investigator and any researcher or other person who contributed to, reviewed, or provided significant input into the research, analysis, writing or conclusions are presented in this submission.

Applicant's Name: Boldyn Networks Infrastructure US LLC
Project Name: MN-07-120527 A
Project Number: N/A

Chris Robinson

Architectural Historian II

Experience:	Employed at EBI since 2020, in the industry since 2017
Education:	MA American History, Southern New Hampshire University BS History and Political Science, Fitchburg State University Archaeological Field Study, The University of Oklahoma
Professional Affiliations and Certifications:	National Trust for Historic Preservation; New England Chapter of the Society of Architectural Historians; Basic of NEPA and Section 106 Integration Advisory Council on Historic Preservations; Environmental and Historic Preservation Considerations / Compliance for Public assistance grants; Strategies for Sustainable Historic Preservation

Chris Robinson has been professionally active in the fields of history and historic preservation since 2017. Through his continuing education and experience, he possesses knowledge and skill with field surveys, material assessments, and NEPA compliance. He meets or exceeds the Secretary of the Interior's Professional Qualifications Standards in the field of History and Architectural History.

Relevant project experience:

National Park Service, Minute Man National Historical Park, Concord, MA

As a park ranger in Concord, Chris staffed multiple historical properties and landscapes providing historical interpretation of the site and the peoples associated. He provided guided tours and lectures of historical resources including properties from the colonial-era to the early 20th-century; battle site exploration; and discussed continuing preservation efforts for buildings and historical landscapes within and related to the park.

National Park Service, Boston National Historical Park, Boston, MA

As a Park Ranger in Boston, Mr. Robinson staffed multiple historic properties and districts providing historical interpretation of the site and the peoples associated. He was also an integral part of the team creating National Historic Landmark nomination for the Robert Gould Shaw Memorial, conducting archival research into the creation and uses of the Memorial proving its NHL eligibility. For his work Mr. Robinson received a 'DI-451 Performance Based Award' approved. Mr. Robinson also created and implemented a new interpretive program, "Meet Me at the Shaw", which discussed the importance of National Historic Landmarks and their connections to the American experience.

Townsend Historical Society, Townsend, MA

In this role, Chris worked as a volunteer archaeologist for the Townsend Historical Society on the Copeland Cooper Shop Preservation project which focused on restoring and preserving the historic Coopering Shop owned by the society. This included historical research, site excavation, artifact conservation and documentation while maintaining Secretary of the Interior Standards.

Other relevant projects and experience Chris has worked on:

- National Historic Landmark nomination for the Robert Gould Shaw Memorial; Chris conducted archival research and created reports towards the nominations of the Robert Gould Shaw Memorial in Boston, MA.
- "Meet Me at the Shaw" interpretive program; Chris created an interpretive program which discussed the importance of National Historic Landmarks and their connections to the American experience.
- Copeland Cooper Shop Preservation project; He conducted field surveys and archaeological excavations while maintaining secretary of the interior standards.
- Chris trained in the preservation and cataloguing of historic and prehistoric artifacts
- Collegiate and graduate-level coursework in architecture, public history and public history strategic management

Summary of Experience

Kelsey Lamkin is experienced in historic preservation and has been professionally active in this field since 2018. She meets the Secretary of the Interior's Professional Qualifications Standards as specified in 36 CFR Part 61 for Architectural History. Prior to joining EBI Consulting in 2022, Ms. Lamkin worked as Historic Preservationist and Tourism Specialist for Memphis Area Association of Governments, where she promoted and advised the public on historic preservation services including cultural resource survey, nomination and facilitation of properties to the National Register of Historic Places, and review of Section 106 survey reports for the region. Before this position, she served as Architectural Historian for Thomason and Associates, Preservation Planners where she conducted Section 106 compliance for a variety of federal projects, completed city design guidelines, and nominated properties and districts to the National Register of Historic Places. Through her education and work, Ms. Lamkin possesses knowledge and skill with architectural assessment, field documentation, report production, and research.

Relevant Project Experience

- Experience in conducting survey and fieldwork for potential historic districts and sites.
- Experience in preparing National Register of Historic Places nominations.
- Skilled in conducting archival research.
- Extensive experience conducting Section 106 compliance.

Education

2018 M.A. Public History, Middle Tennessee State University, Murfreesboro, TN

2016 B.S. Anthropology, Middle Tennessee State University, Murfreesboro, TN

Professional Affiliations

BLDG Memphis

Lynching Sites Project of Memphis, Board Member

Summary of Experience

Alexander (Alex) O’Gorman, M.A., Historian, has five years’ experience in historic preservation. He meets the Secretary of the Interior’s Professional Qualifications Standards as specified in 36 CFR Part 61 for History. Throughout his five years’ experience, Mr. O’Gorman upheld various positions such as a research specialist at three of Preservation Virginia’s historic sites – Patrick Henry’s Scotchtown, The John Marshall House, and Bacon’s Castle; Assistant to the Director of Property Management at the Fairmount Park Conservancy; and as a Historian I with AECOM, Cultural Resources and Historic Preservation. In 2017, Mr. O’Gorman received a Bachelor of Arts in History from Randolph-Macon College, Ashland, VA; and in 2021, he received a Master of Arts in History, concentrating in Public History, from Temple University, Philadelphia, PA. At Temple University, Mr. O’Gorman studied eighteenth and nineteenth century American history, focusing on encounters between Native American and European groups in North America, and the development of the built environment in eighteenth and nineteenth century America. In addition to experience, Mr. O’Gorman holds skills in technical report writing, primary and secondary source research and interpretation, field documentation, architectural assessments, and report production.

At EBI Consulting, Mr. O’Gorman completes all aspects of FCC National Environmental Policy Act (NEPA) compliance reviews and specializes in Section 106 compliance and other cultural resource reviews.

Education

2021 M.A. History, Concentration in Public History, Temple University, Philadelphia, PA

Thesis: [Teedyuscung, A Man, A Statue: Folklore, Stories, and Native American Commemorative Statues and Monuments](#)

2017 B.A. History, Randolph-Macon College, Ashland, VA

Relevant Project Experience (expanded CV available upon request)

EBI CONSULTING- Burlington, MA

Architectural Historian – October 2021 – Present

AECOM, HISTORIC PRESERVATION AND CULTURAL RESOURCE MANAGEMENT-

Burlington, NJ

Historian I – June 2019 – January 2021

At AECOM, Mr. O’Gorman conducted genealogical research compliant with the National Historic Preservation Act, Section 106, examining deeds, titles, directories, atlas maps, newspapers, archeological materials, and architectural sources towards completing genealogical research reports.

THE FAIRMOUNT PARK CONSERVANCY- Philadelphia, PA

Assistant to the Director of Property Management – May 2020 – August 2020

At the Fairmount Park Conservancy, Mr. O’Gorman assisted the Director of Property Management in examining the interior and exterior of 13 historic homes leased by the Fairmount Park Conservancy; and created a Property Inspection Report for each home in compliance with the Secretary of the Interior’s Preservation Standards for Treatment of Historic Properties.

PRESERVATION VIRGINIA

Bacon’s Castle, Surry County, VA

The John Marshall House, Richmond, VA

Patrick Henry’s Scotchtown, Scotchtown, VA

Research Specialist – June 2016 – May 2017

With Preservation Virginia, Mr. O’Gorman completed three research projects for three of Preservation Virginia’s preserved heritage sites. At Bacon’s Castle, he researched the proprietors of Bacon’s Castle, Arthur Allen Senior and Arthur Allen II, and created an unpublished site research report. At The John Marshall House, he led research on free Black societies in Richmond, 1780-1835, and created an unpublished site research report and directory of sources. And, at Patrick Henry’s Scotchtown, he designed and developed a tour which included the histories of Patrick Henry and Nez Perce’s, Chief Joseph.

Professional Affiliations

The National Council of Public History

American Cultural Resources Association

PA Museums

Friends of the Wissahickon

The Fairmount Park Conservancy

SUMMARY OF EXPERIENCE

Stefanie Turner, Architectural Historian, has extensive experience in historic preservation since 2012.

As a Professional Architectural Historian, Ms. Turner meets the Secretary of the Interior professional qualification standards in the areas of Architecture and Historic Preservation as specified by 36CFR61. While earning her Master's of Science in Historic Preservation from Eastern Michigan University, Ms. Turner worked as a Graduate Student Assistant for the Michigan State Historic Preservation Office (SHPO). Her duties at the Michigan SHPO included Section 106 surveys and reviews, project reviews within the Federal Tax credit program, drawing work within the Main Street Program, communication with the public on preservation efforts, and various administrative tasks.

At EBI Consulting, Ms. Turner serves as an Architectural Historian within the West Telecom Environmental practice. Her responsibilities include conducting FCC National Environmental Policy Act (NEPA) and Section 106 Compliance Reviews with a focus on conducting cultural resource surveys and assessing National Register eligibility of historic structures and sites.

RELEVANT PROJECT EXPERIENCE

Ms. Turner has experience surveying historic properties and reviewing applications for US Department of Housing and Urban Development Section 106, as well as reviewing project phase one applications for the Federal Tax credit program. Additionally, she has completed a Condition Assessment Report (CAR) for the Westland City Hall in Westland, Michigan before it was torn down, and a Historic American Buildings Survey (HABS) on an early 1900s Kit Home in Royal Oak, Michigan. Ms. Turner's other experience includes field training in Traverse City, Michigan at the DeYoung Farmstead, part of the Leelanau Conservancy; various tasks for the Michigan Modern initiative, and volunteer work at the Michigan Modern: Designs that Shaped America Symposium.

EDUCATION

M.S. Historic Preservation, Eastern Michigan University, 2015

B.S. Architecture, Lawrence Technological University, 2008

PROFESSIONAL AFFILIATIONS

National Trust for Historic Preservation, 2013 – Present

Michigan Historic Preservation Network, Spring Auction Coordinator, 2013 – 2016

DoCoMoMo_US/MI, Communications Officer, 2015 – 2016

PROFESSIONAL REGISTRATIONS

36 CFR Part 61 Certified since April 2015

Summary of Experience

Mr. Grant completed his formal education in archaeology and meets and/or exceeds the qualifications as outlined in the Secretary of the Interiors Professional Guidelines. He has experience in Section-106 Compliance as it pertains to archaeological Phase I, II, and III excavations. He has been employed in the field of cultural resource management since 2008 and has experience working on both precontact and historic sites across the United States and internationally. He has been involved with archaeological research, writing, and curation since 2006. His focus is material culture studies and historic archaeology of the Southeast.

Mr. Grant's responsibilities at EBI include helping clients navigate the environmental review process to ensure compliance with Federal Communications Commission (FCC) requirements under the National Environmental Policy Act (NEPA). In his role as Project Archaeologist and Principal Investigator for EBI Consulting, Mr. Grant is responsible for completing archaeological evaluations and mitigations for telecoms projects in the Central and Southeastern United States to the standards of relevant State Historic Preservation Offices in accordance with FCC guidelines.

EBI CONSULTING- Burlington, MA

Archaeologist II – Principal Investigator – August 2020 – Present

Please see above for details.

Relevant Project Experience (EXPANDED CV IS AVAILABLE UPON REQUEST)

UNIVERSITY OF CHICAGO – Chicago, IL

Principal Investigator – June 2015-August 2020

In his role as Principal Investigator, Mr. Grant was responsible for research design and implementation of archaeological testing and excavation at 1427 Ursulines Street in historic Faubourg Tremé, New Orleans, Louisiana. Mr. Grant conducted artifact processing and analysis, zooarchaeological analysis, GIS survey, curation, and report writing.

ELOS ENVIRONMENTAL – Hammond, LA

Project Archaeologist – October 2020-December 2020

In his role as Project Archaeologist, Mr. Grant was responsible for directing and leading Phase I and II cultural resource management surveys and excavations at the St. Rosalie Plantation Site in Plaquemines Parish, Louisiana. Additional responsibilities included archaeological monitoring on an active construction site and human osteology.

UNIVERSITY OF CHICAGO – Chicago, IL

Project Archaeologist – June 2012-August 2014

In his role as Project Archaeologist, Mr. Grant conducted archaeological testing and excavations at the site of the Old Ursuline Convent in New Orleans, Louisiana. Additional responsibilities included soil analysis and archaeobotanical processing, laboratory processing, artifact analysis, and report writing.

UNIVERSITY OF NEW ORLEANS – New Orleans, LA

Project Archaeologist – June 2015-August 2016

In his role as Project Archaeologist, Mr. Grant conducted archaeological testing and excavations at 810 Royal Street in New Orleans, Louisiana. He was also responsible for supervising undergraduates at the University of New Orleans Archaeological Field School.

UNIVERSITY OF NEW ORLEANS – New Orleans, LA

Project Archaeologist – June 2013-August 2013

In his role as Project Archaeologist, Mr. Grant conducted archaeological testing and excavations at the site of the Iberville Housing Project in New Orleans, Louisiana. He was also responsible for supervising undergraduates at the University of New Orleans Archaeological Field School.

UNIVERSITY OF CHICAGO – Chicago, IL

Project Archaeologist – June 2008-September 2009

In his role as Project Archaeologist, Mr. Grant was responsible for archaeological testing and excavations at St. Louis Cathedral in New Orleans, Louisiana. Additional responsibilities included artifact processing and analysis and report writing.

GREAT LAKES ARCHAEOLOGICAL RESEARCH CENTER – Milwaukee, WI

Field Technician – June 2008-December 2008

In his role Field Technician, Mr. Grant conducted Phase I archaeological excavations at Midewin National Tallgrass Prairie in Wilmington, Illinois.

Education

M.A.	June 2013	Anthropology	University of Chicago Chicago, IL
M.A.	June 2010	Anthropology (Archaeology track)	Stanford University Stanford, CA
B.A.	June 2008	Anthropology	University of Chicago Chicago, IL

Professional Affiliations

Society for American Archaeology

Society for Historical Archaeology

Louisiana Archaeological Society

SUMMARY OF EXPERIENCE

Ms. Harding completed her formal education in archaeology and exceeds the qualifications for an archaeologist as outlined in the Secretary of the Interior's Professional Guidelines. She is a Register of Professional Archaeologists (RPA) member experienced in Section-106 Compliance as it pertains to archaeological Phase I, II, and III excavations. She has been employed in the field of cultural resource management since 2009 and has experience working on both Precontact and Historic sites across the United States. Her focus is Precontact archaeology of the Northeast and the application of geographic information systems in the field of archaeology.

Ms. Harding's responsibilities at EBI include helping clients navigate the environmental review process to ensure compliance with Federal Communications Commission requirements under the National Environmental Policy Act. In her role as Archaeologist III-Archaeology Operations Manager for EBI Consulting, Ms. Harding is responsible for completing archaeological evaluations and mitigations for telecoms projects in the Mid-Atlantic and Northeastern United States to the standards of relevant State Historic Preservation Offices in the region in accordance with FCC guidelines, evaluations and mitigations for telecoms projects across the United States to the standards of relevant State Historic Preservation Offices, consulting with SHPO and THPO, and managing the archaeology team operating throughout the United States.

EDUCATION

M.S.	December, 2014	Applied Archaeology	Indiana University of Pennsylvania, Indiana, PA.
M.S. Certificate	June, 2014	Geographic Information Systems	Indiana University of Pennsylvania, Indiana, PA
B.S.	June, 2009	Anthropology and Fine Art	St. Lawrence University, Canton, NY

RELEVANT PROJECT EXPERIENCE (EXPANDED CV IS AVAILABLE UPON REQUEST)

September 2020- Present, EBI Consulting

Archaeologist III—Archaeology Operations Manager. Please see above for details.

January 2017-September 2020, EBI Consulting

Archaeologist II—Principal Investigator. In her role as Principal investigator Ms. Harding's responsibilities include helping clients navigate the Section 106 environmental review process, and was responsible for completing archaeological evaluations and mitigations for telecoms projects in the Mid-Atlantic, Northeastern, and Midwest Regions in the United States to the standards of relevant State Historic Preservation Offices, in accordance with FCC guidelines. In addition, Ms. Harding was responsible for reviewing technical archaeological reports.

October 2015-December 2016, TRC Environmental

Project Archaeologist. In her role as Project Archaeologist, Ms. Harding was responsible for directing and leading Phase I, II, and III cultural resource management surveys and excavations throughout the Northeast, Mid-Atlantic, and Midwest Regions. Additional responsibilities included proposal writing, technical report writing, permit writing, conducting background research, and THPO and SHPO consultation.

January 2014-October 2015, TRC Environmental

Archaeological Field Director. In her role as Archaeological Field Director, Ms. Harding was responsible for directing and leading Phase I cultural resource management surveys and excavations throughout the Northeast, Mid-Atlantic, and Midwest Regions. Additional responsibilities included technical report writing, permit writing, and conducting background research.

June 2013 – August 2013, Indiana University of Pennsylvania

Advanced Field School Supervisor. As a graduate student of Applied Archaeology, Ms. Harding was responsible for conducting independent research at the Johnston Precontact Archaeological Site and supervising undergraduate field excavations.

July 2011-January 2014, TRC Environmental

Archaeological Field and GIS Technician. In her role as Archaeological Field and GIS Technician, Ms. Harding was responsible for conducting Phase I and II cultural resource management surveys and excavations throughout the Northeast, Mid-Atlantic, and Midwest Regions. Additional responsibilities included GIS survey for archaeology and other environmental disciplines.

January 2010-November 2010, LSA Associates

Cultural Resource Analyst and Laboratory Technician. In her role as Cultural Resource Analyst and Laboratory Technician, Ms. Harding was responsible for excavation, artifact and soil analysis, artifact photography, curation, and reporting writing.

November 2009-December 2009, Brian F. Smith Associates

Archaeological Laboratory Technician. In her role as Archaeological Laboratory Technician, Ms. Harding was responsible excavation and artifact analysis at the superfund Hanford Construction Site in Washington State. Archaeological monitoring on an active construction site, OSHA HAZWOPER training, historic and precontact artifact analysis, laboratory processing, and curation.

July 2008 – August 2008, Morris Museum, Morristown

Curation Intern. As a Curation Intern, Ms. Harding assisted in conducting curation, cataloging, and public outreach presentations.

July 2006 – August 2006, Lenape Meadow

Volunteer. Ms. Harding volunteered as an excavator on a Paleo-Indian, Archaic, and 18th century multicomponent archaeological site located in Basking Ridge, New Jersey.

PROFESSIONAL AFFILIATIONS

Register of Professional Archaeologists
Society for American Archaeology
Mid-Atlantic Archaeology Conference

CO SUBMISSION PACKET -- FCC FORM 621

Approved by OMB
3060-1039
See instructions for
public burden estimates

Attachment 2. Site Information – Photographs

You are required to provide photographs and maps as part of this filing. Additional site information can be provided in an optional attachment.

Photograph Requirements:

Except in cases where no Historic Properties were identified within the Areas of Potential Effects, submit photographs as described below. Photographs should be in color, marked so as to identify the project, keyed to the relevant map or text, and dated; the focal length of the lens and the height of the camera should be noted. The source of any photograph included but not taken by the Applicant or its consultant (including copies of historic images) should be identified on the photograph.

- a. Photographs taken from the collocation site should show views from the proposed location in all directions. The direction (e.g., north, south, etc.) should be indicated on each photograph, and, as a group, the photographs should present a complete (360 degree) view of the area around the communications tower or non-tower structure.
- b. Photographs of all listed and eligible properties within the Areas of Potential Effects.
- c. If any listed or eligible properties are visible from the proposed collocation site, photographs looking at the site from each historic property. The approximate distance in feet (meters) between the site and the historic property should be included. If any listed or eligible properties are within the APE, photos looking at each historic property should be included.

Include aerial photos of the APE for visual effects, if available. There are a variety of publicly available websites that provide aerial photographs.

Please see the attached photographs, taken by EBI Consulting on October 4, 2023, unless otherwise noted. A photograph location map is included within this attachment.

Applicant's Name: Boldyn Networks Infrastructure US LLC
Project Name: MN-07-120527_A
Project Number: N/A

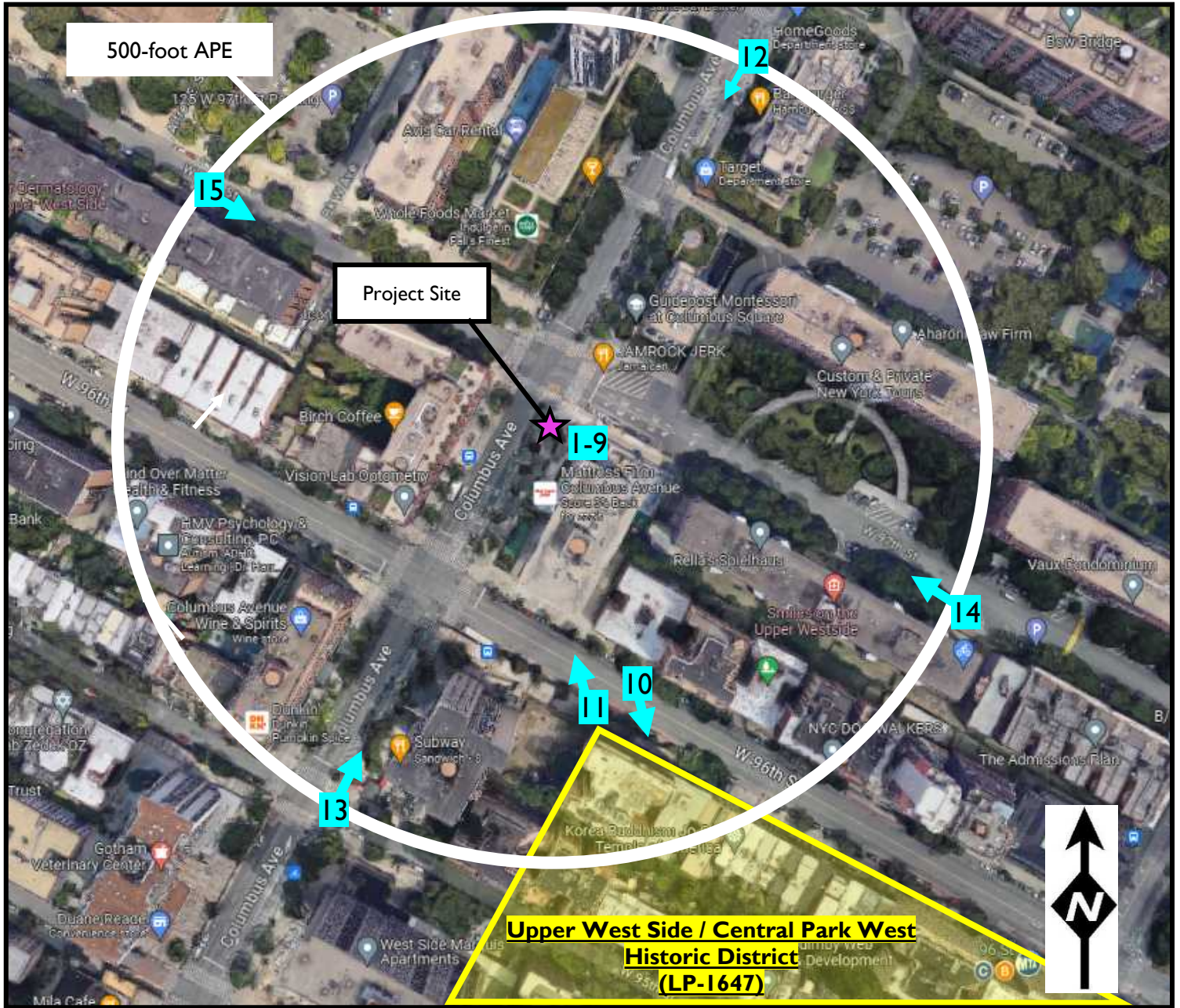

Photo Location Map I (500-Foot APE-VE Radius)

Arrows and numbers indicate the approximate location and direction in which the photograph was taken.

Applicant's Name: Boldyn Networks Infrastructure US LLC

Project Name: MN-07-120527_A

Project Number: N/A

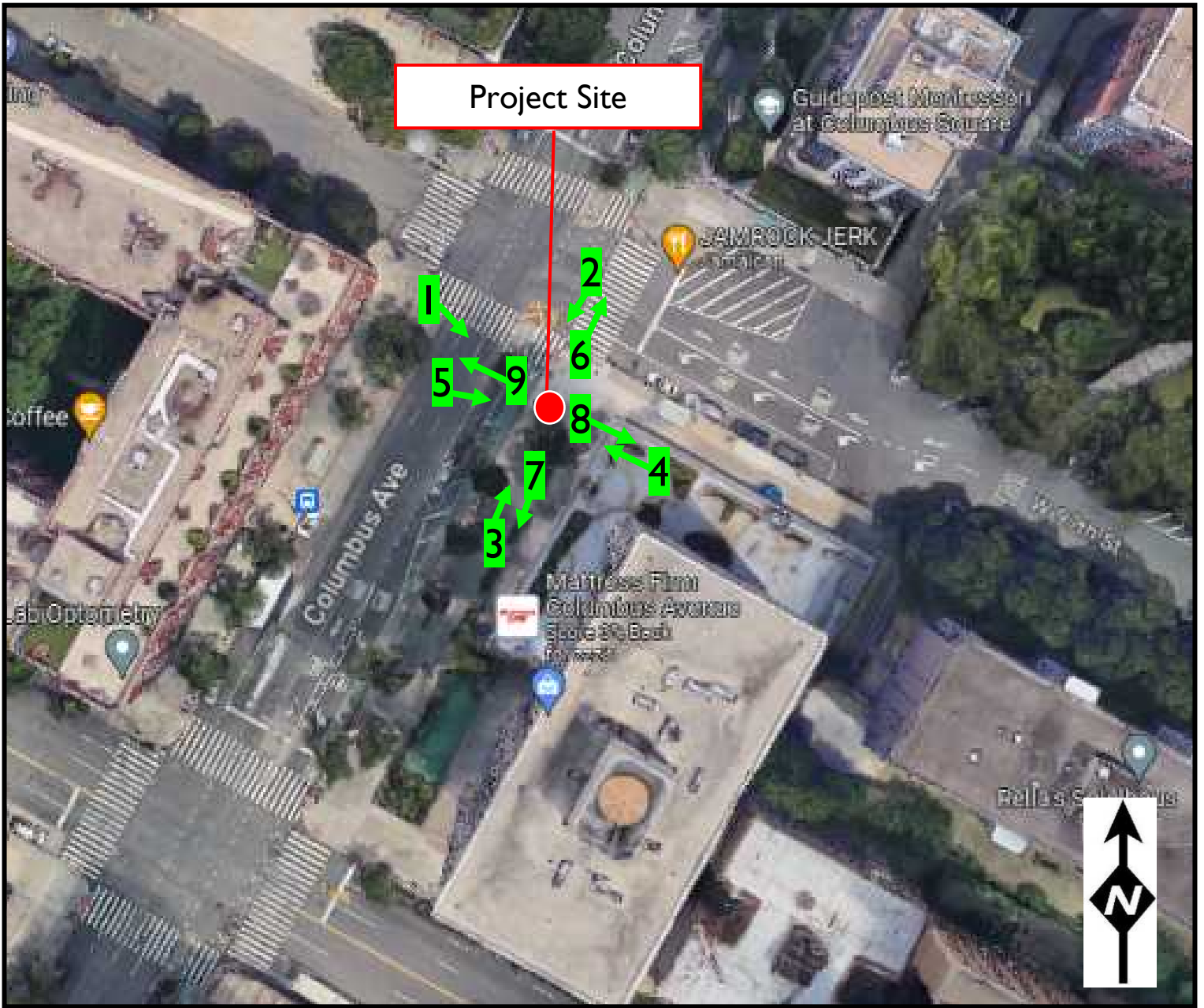

Photo Location Map 2

Arrows and numbers indicate the approximate location and direction in which the photograph was taken.

Applicant's Name: Boldyn Networks Infrastructure US LLC

Project Name: MN-07-120527_A

Project Number: N/A

CO SUBMISSION PACKET -- FCC FORM 621

Approved by OMB
3060-1039
See instructions for
public burden estimates

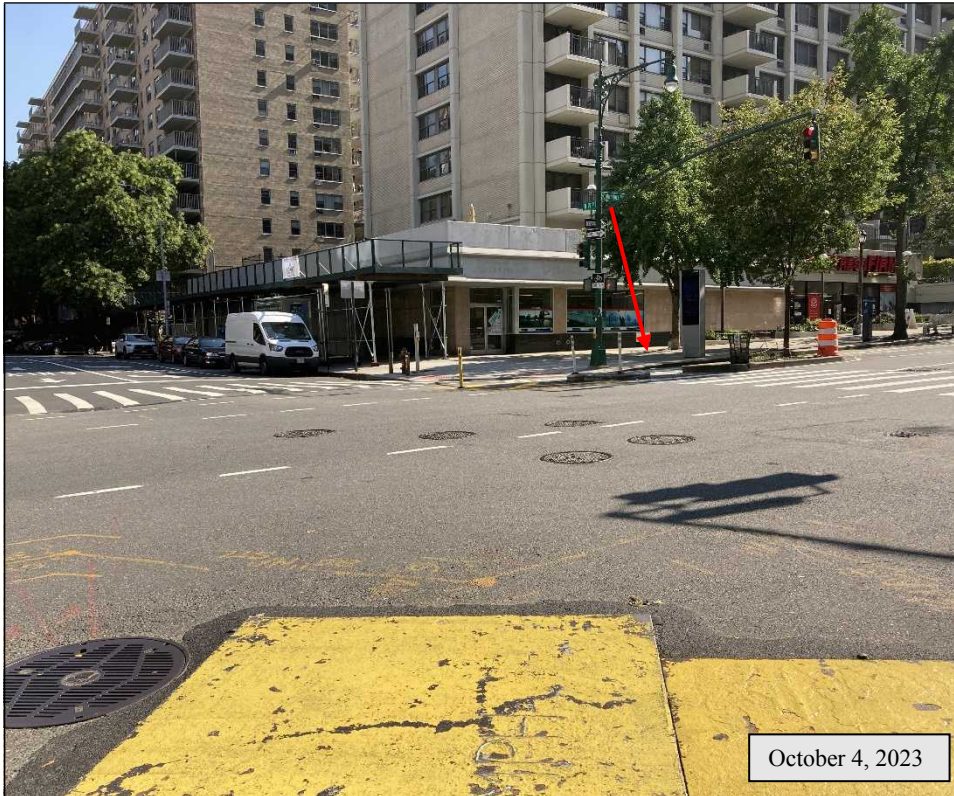

- 1. Overview of the Project Site, indicated by red arrow.



- 2. Facing south overlooking Project Site and structure to be removed, indicated by red arrow.

Applicant's Name: Boldyn Networks Infrastructure US LLC

Project Name: MN-07-120527_A

Project Number: N/A

CO SUBMISSION PACKET -- FCC FORM 621

Approved by OMB

3060-1039

See instructions for public burden estimates

3. Facing north overlooking Project Site and structure to be removed, indicated by red arrow.



October 4, 2023

Applicant's Name: Boldyn Networks Infrastructure US LLC

Project Name: MN-07-120527_A

Project Number: N/A

FCC Form 621

CO SUBMISSION PACKET -- FCC FORM 621

Approved by OMB
3060-1039
See instructions for
public burden estimates



- 4. Facing west overlooking Project Site and structure to be removed, indicated by red arrow.



- 5. Facing east overlooking Project Site and structure to be removed, indicated by red arrow.

Applicant's Name: Boldyn Networks Infrastructure US LLC

Project Name: MN-07-120527_A

Project Number: N/A

CO SUBMISSION PACKET -- FCC FORM 621

Approved by OMB
3060-1039
See instructions for
public burden estimates

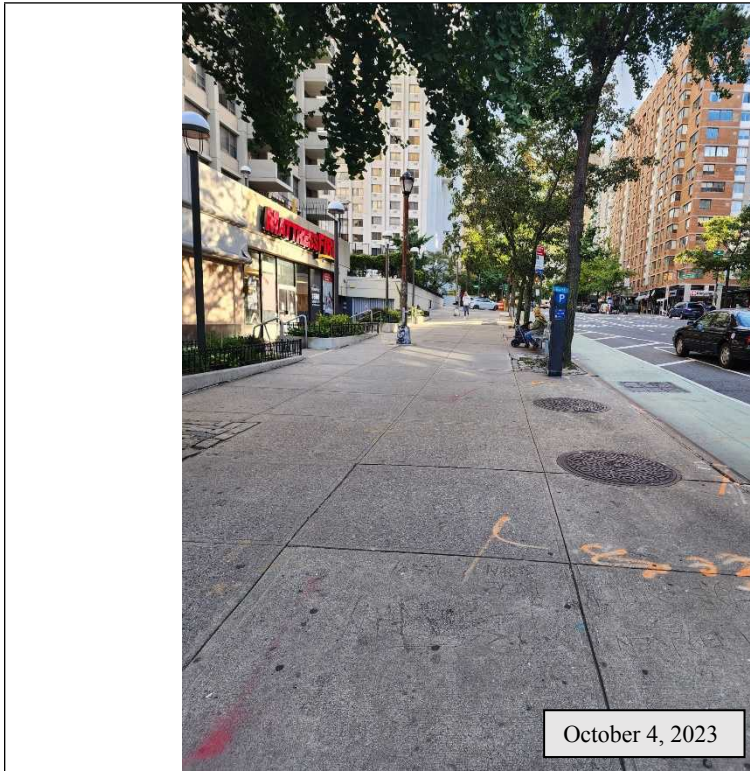

6. Facing north away from Project Site.

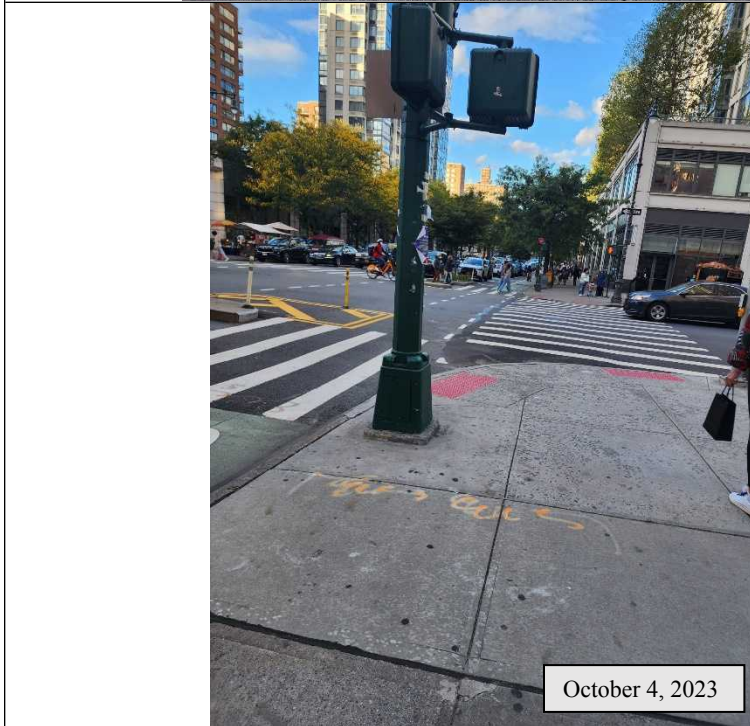

7. Facing south away from Project Site.

Applicant's Name: Boldyn Networks Infrastructure US LLC

Project Name: MN-07-120527_A

Project Number: N/A

CO SUBMISSION PACKET -- FCC FORM 621

Approved by OMB
3060-1039
See instructions for
public burden estimates

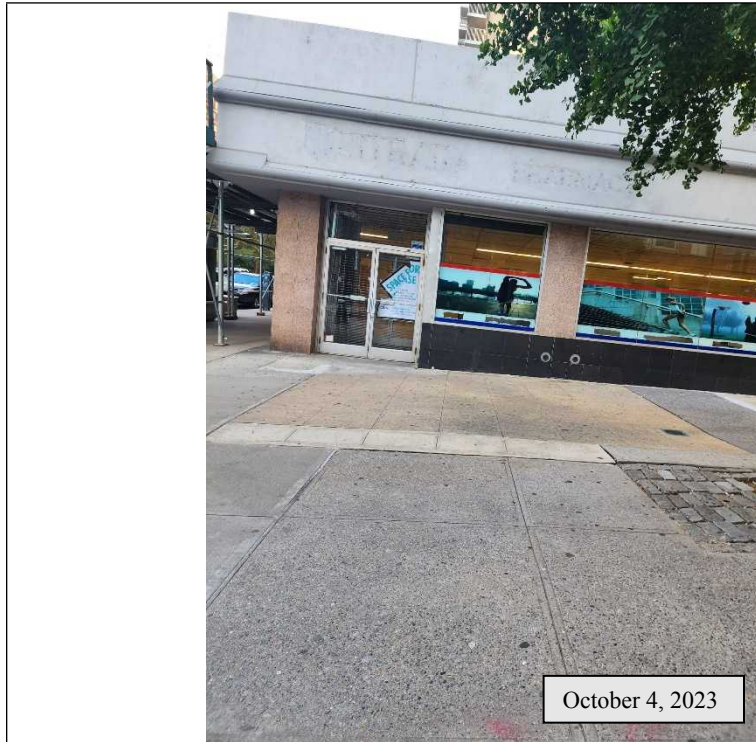

8. Facing east away from Project Site.

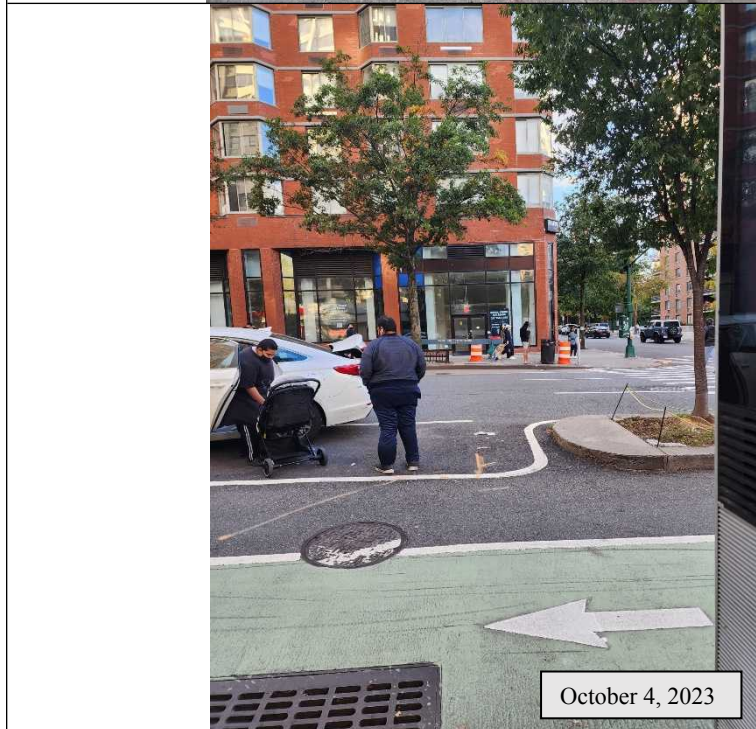

9. Facing west away from Project Site.

Applicant's Name: Boldyn Networks Infrastructure US LLC

Project Name: MN-07-120527_A

Project Number: N/A

CO SUBMISSION PACKET -- FCC FORM 621

Approved by OMB
3060-1039
See instructions for
public burden estimates



10. Facing southeast overlooking Upper West Side / Central Park West Historic District (LP-1647).



11. Facing northwest toward the Project Site (not visible) overlooking the Upper West Side / Central Park West Historic District (LP-1647).

Applicant's Name: Boldyn Networks Infrastructure US LLC

Project Name: MN-07-120527_A

Project Number: N/A

CO SUBMISSION PACKET -- FCC FORM 621

Approved by OMB
3060-1039
See instructions for
public burden estimates

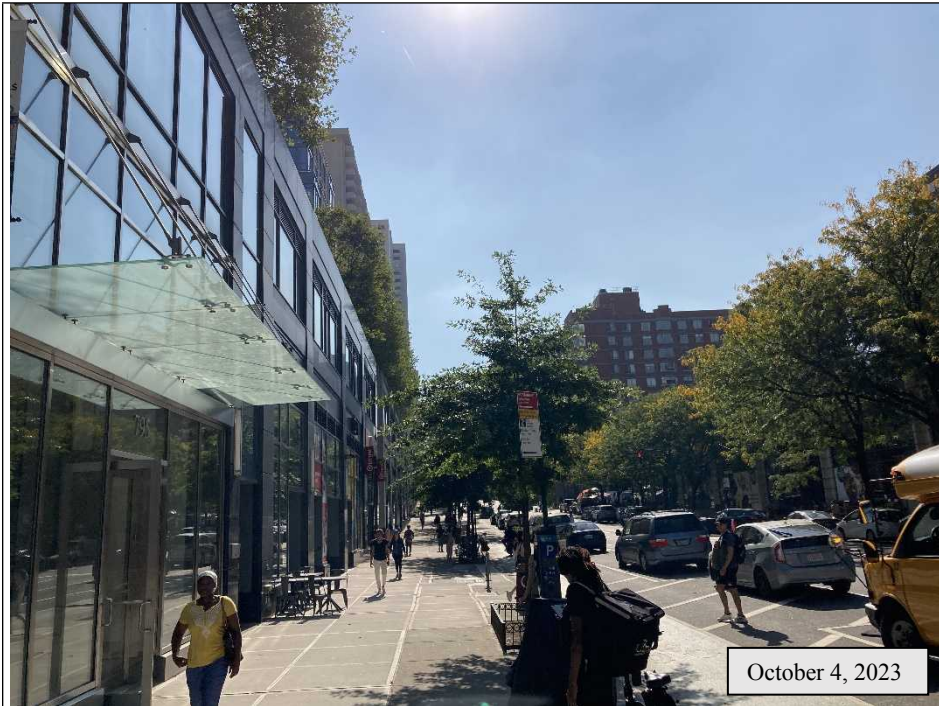

12. View towards the Project Site (not visible) from the northern boundary of the 500-foot APE.



13. View towards the Project Site (not visible) from the southern boundary of the 500-foot APE-VE.

Applicant's Name: Boldyn Networks Infrastructure US LLC

Project Name: MN-07-120527_A

Project Number: N/A

FCC Form 621

CO SUBMISSION PACKET -- FCC FORM 621

Approved by OMB
3060-1039
See instructions for
public burden estimates



October 4, 2023

14. View towards the Project Site (not visible) from the eastern boundary of the 500-foot APE-VE.



October 4, 2023

15. View towards the Project Site (not visible) from the western boundary of the 500-foot APE-VE.

Applicant's Name: Boldyn Networks Infrastructure US LLC

Project Name: MN-07-120527_A

Project Number: N/A

NT SUBMISSION PACKET -- FCC FORM 620

Approved by OMB
3060-1039
See instructions for
public burden estimates

Attachment 3. Site Information - Map Requirements

Include one or more 7.5-minute quad USGS topographical maps that:

- a.** Identify the Areas of Potential Effects for both Direct and Visual Effects. If a map is copied from the original, include a key with name of quad and date.
- b.** Show the location of the proposed undertaking and any new access roads or other easements including excavations.
- c.** Show the locations of each property listed.
- d.** Include keys for any symbols, colors, or other identifiers.
- e.** Submit color maps whenever possible.

The following maps are attached to this report:

Street Map (Figure 1)

Topographic Map (Figure 2)

Aerial Photograph (Please see the Photo Location Map within Attachment 2)

Historic Resources Map

Applicant's Name: Boldyn Networks Infrastructure US LLC
Project Name: MN-07-120527 A
Project Number: N/A



EBI GIS, Sources: Esri, HERE, Garmin, USGS, Intermap, INCREMENT P, NRCan, Esri Japan, METI, Esri China (Hong Kong), Esri Korea, Esri (Thailand), NGCC, (c) OpenStreetMap contributors, and the GIS User Community

Legend

- ★ Project Site
- Site Radius at 250', 500', 1000' and 1/2 mile

Date: 9/12/2023

Figure 1: Site Location Map

MN-07-120527_A
741 COLUMBUS AVENUE
NEW YORK, NY 10025

PN: 6123006709





EBI Consulting
 environmental | engineering | design



EBI GIS, Copyright:© 2013 National Geographic Society, i-cubed

Legend

- ★ Project Site
- Site Radius at 250', 500', 1000' and 1/2 mile

USGS 24K Quad: Central Park, NY 1986

Date: 9/12/2023

Figure 2 - Topographic Map

MN-07-120527_A
741 COLUMBUS AVENUE
NEW YORK, NY 10025

PN: 6123006709





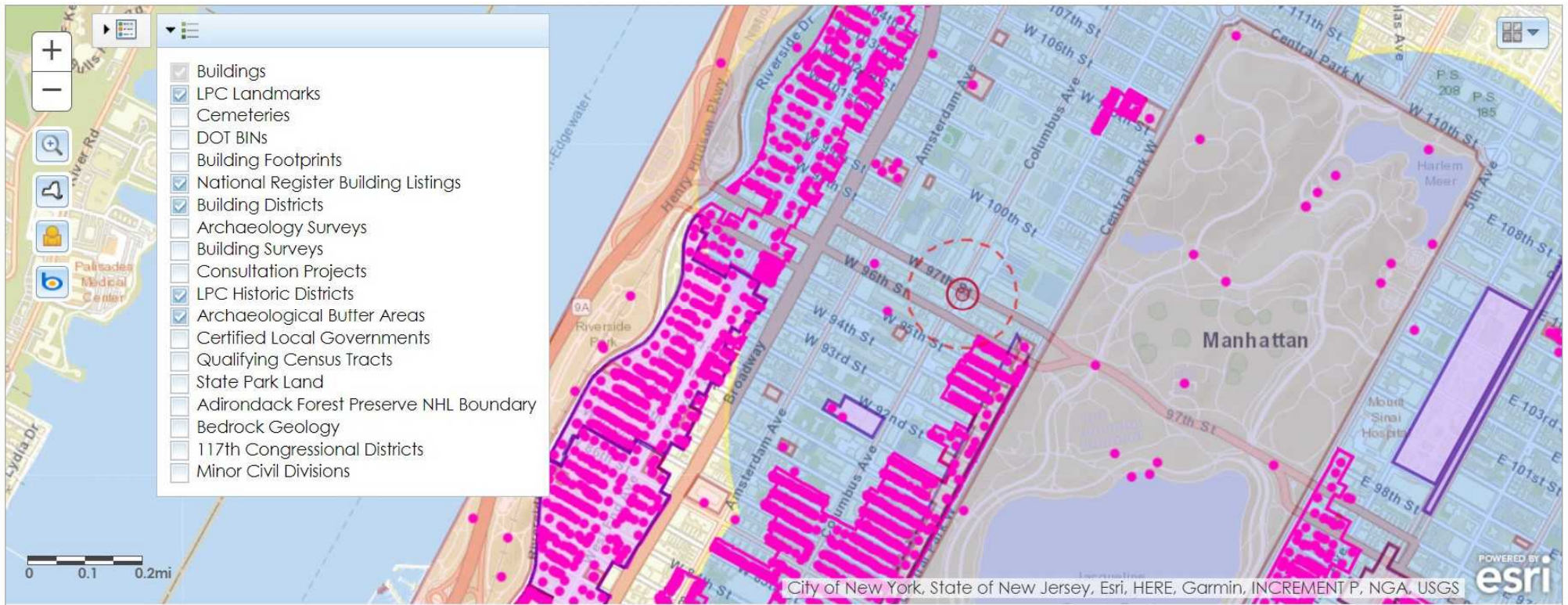



Discover New York City Landmarks

Data and Map Feedback



40°47'36.2"N 73°58'01.2"W

Show search results for 40°47'36.2"N...

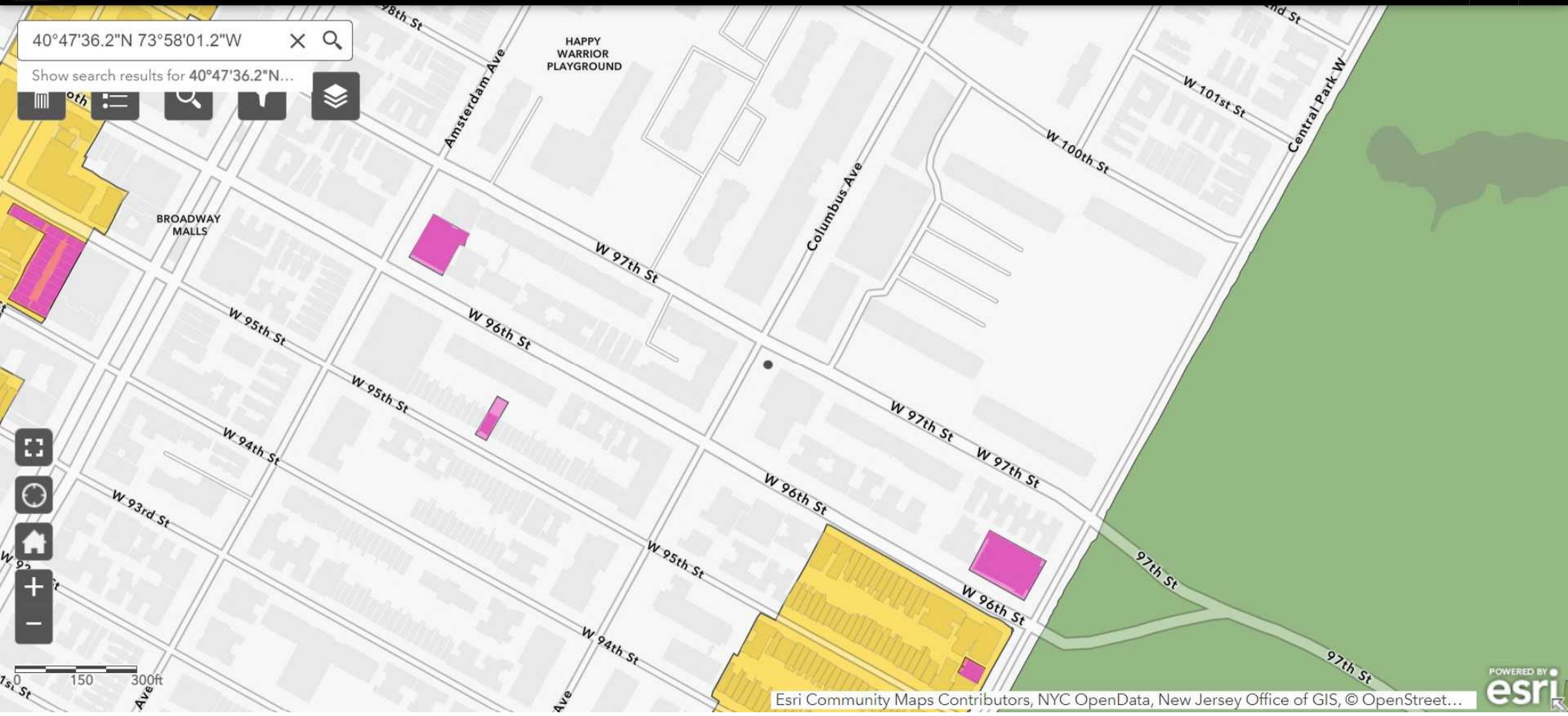

Esri Community Maps Contributors, NYC OpenData, New Jersey Office of GIS, © OpenStreet...



Attachment 4. Site Information – Additional Site Information

Additional Site Information Recommendations:

Describe any additional structures, access roads, utility lines, fences, easements, or other construction planned for the site in conjunction with the proposed wireless telecommunication facility. Use this attachment to provide additional details needed to present a full and accurate description of any construction activities that will take place to complete the installation.

The Subject Property, located near 741 Columbus Avenue, New York, New York County, NY 10025, is situated within a predominantly mixed-use commercial and multi-family residential urban neighborhood. The buildings are primarily multi-story construction from the nineteenth through the twenty-first centuries with moderate degrees of integrity along rectilinear lots. The terrain has no significant elevation changes and includes paved roads and parking lots, concrete sidewalks and curbs, traffic and utility infrastructure, street signage, recreational parks, and modest landscaping with mature trees throughout the area.

The Subject Property consists of an existing display unit structure within a portion of the Columbus Avenue right-of-way, at the intersection with W 97th Street. Improvements to the Subject Property include asphalt paved roads, concrete sidewalks, steel and concrete curbs, traffic signage, landscaped areas, utility manholes, and below ground utilities, including power, water, and sewer lines.

Boldyn Networks Infrastructure US LLC proposes to remove an existing display unit structure and install a new pole with top-mounted antennas for an overall height of 32.5 feet at the Subject Property. The pole and support equipment will be installed within an estimated 5-foot by 5-foot installation area, located on a sidewalk in the Columbus Avenue right-of-way, on the east side of the street. Power will be routed underground from an existing manhole in the intersection of Columbus Avenue with W 97th Street approximately 66 feet southwest to the proposed pole. Fiber will be routed underground from an existing manhole approximately 15 feet northeast to the proposed pole. Trenching for utilities is not anticipated to exceed 3 feet in width and 4 feet in depth. Access will be gained via the existing road right-of-way. Per the Federal Communications Commission’s (FCC) definition, the Area of Potential Effect-Direct Effects (APE-DE) at grade consists of the pole installation area, underground utility easements, and access route. Note that establishing the access route will not require new ground disturbance. The total area of ground disturbed was approximately 268 square feet.

Site Plans/Lease Exhibits provided by Boldyn Networks Infrastructure US LLC are included in Attachment 7.

Applicant’s Name: Boldyn Networks Infrastructure US LLC
Project Name: MN-07-120527 A
Project Number: N/A

Attachment 5. Area of Potential Effects

You are required to provide two attachments regarding the Determination of Effect: Areas of Potential Effect and Mitigation of Effect (if applicable).

Areas of Potential Effect Guidelines:

a. Describe the APE for direct effects and explain how this APE was determined.

The APE for direct effects is limited to the area of potential ground disturbance and any property, or any portion thereof, that will be physically altered or destroyed by the Undertaking. On November 24, 2008, the FCC further clarified that the APE-Direct Effects is limited to the proposed lease area including the access route and utility corridor. EBI Consulting completed an evaluation of the site, lease exhibits, and surrounding environment and determined that the APE for direct effects is limited to the pole installation area and underground utility easements.

b. Describe the APE for visual effects and explain how this APE was determined.

The APE for visual effects is the geographic area in which the Undertaking has the potential to introduce visual elements that diminish or alter the setting, including the landscape, where the setting is a character-defining feature of a historic property that makes it eligible for listing on the National Register.

According to the guidance in Section VI.C of the FCC's 2004 NPA, the presumed APE for visual effects for construction of new facilities under 200 feet in total overall height is the area from which the tower will be visible within a half mile from the tower site. However, per Section VI.C.5 of the FCC's 2004 NPA, "in the event that the Applicant determines, or the SHPO/THPO recommends, that an alternative APE for visual effects is necessary, the Applicant and the SHPO/THPO may mutually agree to an alternative APE." In consultation with the FCC, it has been determined that a 500-foot radius around the project site is an appropriate APE-VE for the vast majority of the CityBridge Link5G sites. Factors such as the height of the undertaking, the density of the development within the project area, and the presence of existing structures and vegetation in the public right of way were considered per the FCC's guidance in the NPA. The area surrounding the project site shares the characteristics cited by the FCC so it has been determined that 500-foot is an appropriate radius for assessing the effects of the project on historic properties, if any exist.

Mitigation of Effect Guidelines:

In the case where an Adverse Visual Effect or Adverse Direct Effect has been determined you must provide the following:

a. Copies of any correspondence and summaries of any oral communications with the SHPO/THPO and any consulting parties.

As of the date of this report, there has been no correspondence with the SHPO/THPO.

b. Describe any alternatives that have been considered that might avoid, minimize, or mitigate any adverse effects. Explain the Applicant's conclusion regarding the feasibility of each alternative.

No adverse effects are expected as a result of the proposed facility; therefore, alternatives that might avoid, minimize, or mitigate any adverse effects need not be considered.

For each property identified as a Historic Property in the online e-106 form:

Applicant's Name: Boldyn Networks Infrastructure US LLC
Project Name: MN-07-120527 A
Project Number: N/A

NT SUBMISSION PACKET -- FCC FORM 620

Approved by OMB

3060-1039

See instructions for
public burden estimates

Indicate whether the Applicant believes the proposed undertaking would have a) no effect; b) no adverse effect; or, c) an adverse effect. Explain how each such assessment was made. Provide supporting documentation where necessary.

Please see the table below for an evaluation of the proposed project's effects on identified historic properties.

NRHP/ Inventory Number	Historic Property Name	Effect Determination	Explanation of Effect Determination	EBI Photo No.
LP-1647	Upper West Side / Central Park West Historic District (NYC LPC Landmark HD)	No Effect	<p>The Subject Property is within the APE-VE, approx. 500 feet southeast of the Subject Property.</p> <p>The installation will not be visible from the resource due to intervening buildings. Therefore, the installation will have no effect on the resource.</p>	10-11

Applicant's Name: Boldyn Networks Infrastructure US LLC
 Project Name: MN-07-120527 A
 Project Number: N/A

Attachment 6. Tribal and NHO Involvement

At an early stage in the planning process, the Nationwide Agreement requires the Applicant to gather information from appropriate Indian Tribes or Native Hawaiian Organizations (“NHOs”) to assist in the identification of Historic Properties of religious and cultural significance to them. Describe measures taken to identify Indian tribes and NHOs that may attach religious and cultural significance to Historic Properties that may be affected by the undertaking within the Areas of Potential Effects (“APE”) for direct and visual effects. If such Indian tribes or NHOs were identified, list them and provide a summary of contacts by either the FCC, the Applicant, or the Applicant’s representative. Provide copies of relevant documents, including correspondence. If no such Indian tribes or NHOs were identified, please explain.

EBI Consulting filed the proposed undertaking on the FCC’s Tower Construction Notification System (TCNS). The attached FCC Notification email lists the Tribes identified through the TCNS process. Follow-up correspondence, when necessary, will be completed via the methods listed on the attached email considered acceptable to each Tribe.

Applicant’s Name: Boldyn Networks Infrastructure US LLC
Project Name: MN-07-120527 A
Project Number: N/A

From: towernotifyinfo@fcc.gov
To: [Angela Blankenship](#)
Cc: tcnsweekly@fcc.gov
Subject: NOTICE OF ORGANIZATION(S) WHICH WERE SENT PROPOSED TOWER CONSTRUCTION NOTIFICATION INFORMATION - Email ID #8681157
Date: Friday, October 6, 2023 2:01:13 AM

Dear Applicant:

Thank you for using the Federal Communications Commission's (FCC) Tower Construction Notification System (TCNS). The purpose of this electronic mail message is to inform you that the following authorized persons were sent the notification that you provided through TCNS, which relates to your proposed antenna structure. The information was forwarded by the FCC to authorized TCNS users by electronic mail and/or regular mail (letter). We note that the review period for all parties begins upon receipt of the Submission Packet pursuant to Section VII.A of the NPA and notifications that do not provide this serve as information only.

Persons who have received the notification that you provided include leaders or their designees of federally-recognized American Indian Tribes, including Alaska Native Villages (collectively "Tribal Nations"), Native Hawaiian Organizations (NHOs), and State Historic Preservation Officers (SHPOs). For your convenience in identifying the referenced Tribal Nations and NHOs and in making further contacts, the City and State of the Seat of Government for each Tribal Nation and NHO, as well as the designated contact person, is included in the listing below. We note that Tribal Nations may have Section 106 cultural interests in ancestral homelands or other locations that are far removed from their current Seat of Government. Pursuant to the Commission's rules as set forth in the Nationwide Programmatic Agreement for Review of Effects on Historic Properties for Certain Undertakings Approved by the Federal Communications Commission (NPA), all Tribal Nations and NHOs listed below must be afforded a reasonable opportunity to respond to this notification, consistent with the procedures set forth below, unless the proposed construction falls within an exclusion designated by the Tribal Nation or NHO. (NPA, Section IV.F.4).

The notification that you provided was forwarded to the following Tribal Nations and NHOs. A Tribal Nation or NHO may not respond until a full Submission Packet is provided. If, upon receipt, the Tribal Nation or NHO does not respond within a reasonable time, you should make a reasonable effort at follow-up contact, unless the Tribal Nation or NHO has agreed to different procedures (NPA, Section IV.F.5). In the event a Tribal Nation or NHO does not respond to a follow-up inquiry, or if a substantive or procedural disagreement arises between you and a Tribal Nation or NHO, you must seek guidance from the Commission (NPA, Section IV.G). These procedures are further set forth in the FCC's Second Report and Order released on March 30, 2018 (FCC 18-30).

1. TCNS Coordinator Tiffany Martinez - Delaware Nation - 31064 State Highway 281 (PO Box: 825) Anadarko, OK - tmartinez@delawarenation-nsn.gov - 405-247-2448 (ext: 1403) - electronic mail

Exclusions: The Delaware Nation of Oklahoma Historic Preservation Office has developed the following consultation procedures for all TCNS projects identified as undertakings by the

Federal Communications Commission. In the email subject line, please specify whether the project is for a tower, small cell, or collocation. Our response can be given faster with this information.

2. Cayuga Nation Representative Clint C Halftown - Cayuga Nation - (PO Box: 803) Seneca Falls, NY - clinta@roadrunner.com; tina.orbaker@gmail.com - 315-568-0750 - regular mail

If the applicant/tower builder receives no response from the Cayuga Nation within 30 days after notification through TCNS, the Cayuga Nation has no interest in participating in pre-construction review for the proposed site. The Applicant/tower builder, however, must immediately notify the Cayuga Nation in the event archaeological properties or human remains are discovered during construction, consistent with Section IX of the Nationwide Programmatic Agreement and applicable law.

3. THPO Lawrence Plucinski - Bad River Band of Lake Superior Tribe of Chippewa Indians - (PO Box: 39) Odanah, WI - thpo@badriver-nsn.gov; deputyTHPO@badriver-nsn.gov - 715-682-7123 - electronic mail

If the applicant/tower builder receives no response from the Bad River Band of Lake Superior Tribe of Chippewa Indians within 30 days after notification through TCNS, the Bad River Band of Lake Superior Tribe of Chippewa Indians has no interest in participating in pre-construction review for the proposed site. The Applicant/tower builder, however, must immediately notify the Bad River Band of Lake Superior Tribe of Chippewa Indians in the event archaeological properties or human remains are discovered during construction, consistent with Section IX of the Nationwide Programmatic Agreement and applicable law.

4. THPO Marvin DeFoe - Red Cliff Band of Lake Superior Chippewa Indians of Wisconsin - 88455 Pike Road, HWY 13 Bayfield, WI - Marvin.DeFoe@redcliff-nsn.gov; Edwina.Buffalo-Reyes@redcliff-nsn.gov - 715-779-3761 - electronic mail

Exclusions: Boozhoo, we do not have the Red Cliff Portal site online anymore and apologize for the inconvenience.

If you have a project that has already been paid for or would like to voluntarily pay for, please email documents for project review to THPO@redcliff-nsn.gov. This address is only to be used by Consultants who are voluntarily paying for projects.

If you have any questions, please contact Marvin Defoe, THPO Manager at (715) 779-3700 Ext. 4244 or Edwina Buffalo-Reyes, THPO Assistant at (715) 779-3700 Ext. 4243.

5. Tribal Historic Preservation Officer Jeff Bendremer - Stockbridge-Munsee Band of Mohican Indians - Historic Preservation Extension Office 86 Spring Street Williamstown, MA - thpo@mohican-nsn.gov - 413-884-6029 - electronic mail

Exclusions: The Stockbridge-Munsee Community reviews all cell tower construction projects that result in ground-disturbance in its areas of interest. Our areas of interest are Wisconsin, New York, Vermont, Massachusetts, the northwest corner of Connecticut, Pennsylvania, New Jersey and Kansas.

However, effective August 1, 2018, the Stockbridge-Munsee Community will only provide a reply to projects where, after completing its assessment, it has determined that it has concerns about the project. We are not interested in reviewing projects that do not result in ground disturbance, and will not respond to such projects.

If you are sending a ground disturbing project please include colored pictures of the site area along with colored maps and any known ground disturbance that preceded your current project.

If the applicant/tower builder receives no response from the Stockbridge-Munsee Band of Mohican Indians within 30 days after notification through TCNS, the Stockbridge-Munsee Band of Mohican Indians has no interest in participating in pre-construction review for the proposed site. The Applicant/tower builder, however, must immediately notify the Stockbridge-Munsee Band of Mohican Indians in the event archaeological properties or human remains are discovered during construction, consistent with Section IX of the Nationwide Programmatic Agreement and applicable law.

6. Cell Tower Coordinator Kelly Nelson - Eastern Shawnee Tribe of Oklahoma - 70500 East 128 Road Wyandotte, OK - celltower@estoo.net - 918-238-5151 (ext: 1861) - regular mail
Exclusions: DO NOT EMAIL DOCUMENTATION; it will be deleted without being opened. Submit one printed color copy by US postal mail or other parcel carrier of all documentation to:

Eastern Shawnee Tribe
Attn: CellTower Program
70500 E. 128 Rd.
Wyandotte, OK 74370

Provide a 1-page cover letter with the following information:

- a. TCNS Number
- b. Company Name

- c. Project Name, City, County, State
- d. Project type
- e. Project coordinates
- f. Contact information

The Eastern Shawnee Procedures document is available and highly recommended for guidance; send an email to celltower@estoo.net requesting our most current copy.

7. THPO Sherri Clemons - Wyandotte Nation - 8 Turtle Drive Wyandotte, OK - sclemons@wyandotte-nation.org - 918-678-6344 - electronic mail

Exclusions: Please refrain from sending information via mail. We ONLY accept information via email to: sclemons@wyandotte-nation.org. We will advise if we require additional information.

8. THPO Sarah E Thompson - Lac du Flambeau Band of Lake Superior Chippewa Indians - Tribal Historic Preservation Office (PO Box: 67) Lac du Flambeau, WI - ldfthpo@ldftribe.com - 715-588-2139 - electronic mail

Exclusions: Effective Immediately:

Please send all submissions through email until further notice. Effective 3/23/2020

Please email all submissions to ldfthpo@ldftribe.com

Thank you

9. Deputy THPO, Archaeologist Susan Bachor - Delaware Tribe of Indians - 126 University Circle Stroud Hall, Rm. 437 East Stroudsburg, PA - sbachor@delawaretribe.org;

lheady@delawaretribe.org - 610-761-7452 - electronic mail

Exclusions: The Delaware Tribe of Indians areas of interest include our aboriginal territories (circa 1600), known locations of historic Delaware settlements, routes of removal and forced migration, and all lands of Delaware aboriginal title ceded by treaty to the United States. If you are receiving this notification, then your project falls within these areas of interest and we ask that you provide us with a cover letter describing the project and its location (including the project coordinates) as well as a topographic map showing the project location. If an archaeological survey has already been performed in preparation for the project, please send a copy of that as well. Additionally, we may request a biological assessment of culturally significant treaty resources which may be affected by the proposed undertaking.

We are only interested in consulting on projects that involve ground disturbance that is planned to take place in both undisturbed and previously disturbed contexts. We are not interested in consulting on collocations or projects that involve no ground disturbance. If your project does involve ground disturbance or you do not receive a response from us within 30 days of submitting the above project information, then we have no comments on the project. However, if any archaeological resources or human remains are disturbed at any point in the project planning or construction, we ask that the project be halted until we can be notified of the inadvertent discovery and can determine the most appropriate course of action. If your company would like a formal written response from the Delaware Tribe concerning the potential impact of your project to culturally and religiously significant sites, please contact Susan Bachor at sbachor@delawaretribe.org to request such a response.

In order to better facilitate consultation throughout our areas of interest we have three regional tribal historic preservation offices. While our Tribal Headquarters remains in Oklahoma, our Eastern Office in Pennsylvania is the point of contact for all consultation within our Eastern Region which includes the states of Massachusetts, Connecticut, New York, New Jersey, Pennsylvania, Delaware, Maryland and Virginia. If your project exists in any of these states, please contact Susan Bachor with the above project information at the following e-mail address. All offices prefer digital submissions and the project information can be submitted by e-mail.

Susan Bachor, Acting Director of Historic Preservation
Eastern Office
126 University Circle
Stroud Hall, Rm. 437
East Stroudsburg PA 18301
(610) 761-7452
sbachor@delawaretribe.org

Our Midwestern office is the point of contact for all consultation within our Midwestern region which includes the states of West Virginia, Ohio, Indiana, Michigan and Illinois. If your project exists in any of these states, please contact Larry Heady with the above project information at the following e-mail address. Our Midwestern office prefers to receive digital submissions and the project information can be submitted by e-mail.

Larry Heady, THPO
Midwestern Office
125 Dorry Lane, Grants Pass, OR 97527
lheady@delawaretribe.org
(262) 825-7586

We, at the Delaware Tribe Historic Preservation Office, along with our Chief and Tribal Council remain committed to protecting the cultural and physical integrity of our historic sites, traditional cultural properties, sacred sites, objects of cultural patrimony, and most importantly, the remains of our Ancestors. We look forward to working with you on our shared interests in preserving and protecting Delaware heritage within our areas of interest.

The notification that you provided was also forwarded to the following SHPOs in the State in which you propose to construct and neighboring States. The information was provided to these SHPOs as a courtesy for their information and planning. You need make no effort at this time to follow up with any SHPO that does not respond to this notification. Prior to construction, you must provide the SHPO of the State in which you propose to construct (or the Tribal Historic Preservation Officer, if the project will be located on certain Tribal lands), with a Submission Packet pursuant to Section VII.A of the NPA unless the project is excluded from SHPO review under Section III D or E of the NPA.

10. SHPO Cara Metz - Massachusetts Historical Commission - 220 Morrissey Boulevard Boston, MA - cara.metz@sec.state.ma.us - 617-727-8470 - electronic mail

11. Historic Preservation Supervisor Barbara Frederick - Pennsylvania State Historic Preservation Office - Pennsylvania Historical & Museum Commission 400 North St, 2nd Floor Harrisburg, PA - bafrederic@pa.gov - 717-772-0921 - electronic mail

12. SHPO Laura V Trieschmann - Vermont Division for Historic Preservation - National Life Building Drawer 20 Montpelier, VT - laura.trieschmann@vermont.gov - 802-828-3222 - electronic mail

TCNS automatically forwards all notifications to all Tribal Nations and SHPOs that have an expressed interest in the geographic area of a proposal. However, if a proposal for PTC wayside poles falls within a designated exclusion, you need not expect any response and need not pursue any additional process with that Tribal Nation or SHPO. In addition, a particular Tribal Nation or SHPO may also set forth policies or procedures within its details box that exclude from review certain facilities (for example, a statement that it does not review collocations with no ground disturbance; or that indicates that no response within 30 days indicates no interest in participating in pre-construction review).

Please be advised that the FCC cannot guarantee that the contact(s) listed above have opened and reviewed an electronic or regular mail notification. If you learn that any of the above

contact information is no longer valid, please contact the FCC by emailing tenshelp@fcc.gov. The following information relating to the proposed tower was forwarded to the person(s) listed above:

Notification Received: 09/28/2023

Notification ID: 272298

Excluded from SHPO Review: No

Tower Owner Individual or Entity Name: Boldyn Networks Infrastructure US LLC

Consultant Name: Angela Blankenship

Street Address: 23 Bronson Pt Apt 311

City: Lebanon

State: TENNESSEE

Zip Code: 37087

Phone: 317-938-0708

Email: ablankenship@ebiconsulting.com

Structure Type: POLE - Any type of Pole

Latitude: 40 deg 47 min 36.2 sec N

Longitude: 73 deg 58 min 1.2 sec W

Location Description: 741 Columbus Avenue

City: New York

State: NEW YORK

County: NEW YORK

Detailed Description of Project: Proposed telecommunications facility resulting in minimal ground disturbance. Please see Attachment 4 of this filing for project design details.

6123006709

Ground Elevation: 29.9 meters

Support Structure: 9.8 meters above ground level

Overall Structure: 9.8 meters above ground level

Overall Height AMSL: 39.7 meters above mean sea level

If you have any questions or comments regarding this notice, please contact the FCC using the electronic Help Request form located on the FCC's website at:

<https://www.fcc.gov/wireless/available-support-services>

You may also call the FCC Support Center at (877) 480-3201 (TTY 717-338-2824). Hours are from 8:00 a.m. to 6:00 p.m. Eastern Time, Monday through Friday (except Federal holidays). To provide quality service and ensure security, all telephone calls are recorded.

Thank you,
Federal Communications Commission

References

Federal Communications Commission (FCC)

- 2004 *Nationwide Programmatic Agreement Regarding the Section 106 National Preservation Act Review Process, Report and Order, FCC 04-222*. Annotated version showing later technical and officially adopted revisions available from the Federal Communications Commission website at <https://www.fcc.gov/document/nationwide-programmatic-agreement-regarding-section-106-national-0>.

Google Earth

- 2023 <https://www.google.com/earth/> Accessed: October 5, 2023.

Nationwide Environmental Title Research (NETR)

- 2023 <https://www.historicaerials.com/viewer> Accessed: October 5, 2023.

New York Cultural Resource Information System (CRIS)

- 2023 <https://cris.parks.ny.gov/Default.aspx> Accessed September 25, 2023

The New York Public Library

- 2019a *A Plan of New York and Long Island 1776* <https://www.nypl.org/collections/nypl-recommendations/guides/historical-nyc-maps-atlases>. Accessed October 5, 2023.
- 2019b *Sidney's map of twelve miles around New-York: with the names of property holders, &c., from entirely new & original surveys 1856* <https://www.nypl.org/collections/nypl-recommendations/guides/historical-nyc-maps-atlases>. Accessed October 5, 2023.

United States Department of the Interior

- 1983 *Archaeology and Historic Preservation: Secretary of the Interiors Standards and Guidelines. Federal Register Part IV, 48(2):44716-44742*. Annotated version showing later technical and officially adopted revisions available from the National Park Service's preservation laws, regulations, and standards webpage at https://www.nps.gov/history/local-law/arch_stnds_0.htm.

United States Geological Service (USGS)



- 1891 *Harlem, New Jersey 15' Topographic Quadrangle*. USGS, Washington, D.C.
- 1947 *Central Park, New York 15' Topographic Quadrangle*. USGS, Washington, D.C.
- 1986 *Central Park, New York 7.5' Topographic Quadrangle*. USGS, Reston, Virginia.

Web Soil Survey (WSS)

- 2023 United States Department of Agriculture soils website. <http://websoilsurvey.nrcs.usda.gov/app/WebSoilSurvey.aspx>. Accessed: October 5, 2023.



USGS Quad Location Map

-  Lease Area / Access Easement
-  Project Site
-  Site Radius at 1/2 & 1 mile

MN-07-120527_A

741 COLUMBUS AVENUE
New York, New York 10025

USGS 24K Quad: Central Park, NY 1986

Section Township Range: not in PLSS

Easting and Northing: 587147E 4516334N
Longitude and Latitude: 73.967012°W 40.793379°N

Spatial Reference
Coordinate System: NAD 1983 UTM Zone 18N
Projection: Transverse Mercator
Datum: North American 1983



Source: Selected data from ESRI, Google and EBI.

Project #
6123006709

Created By
EBI GIS
Date: 9/25/2013

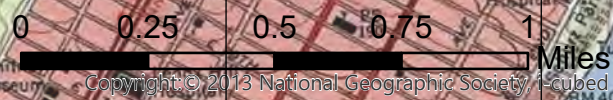

Copyright © 2013 National Geographic Society

County Location



★ Project Site

County of Interest

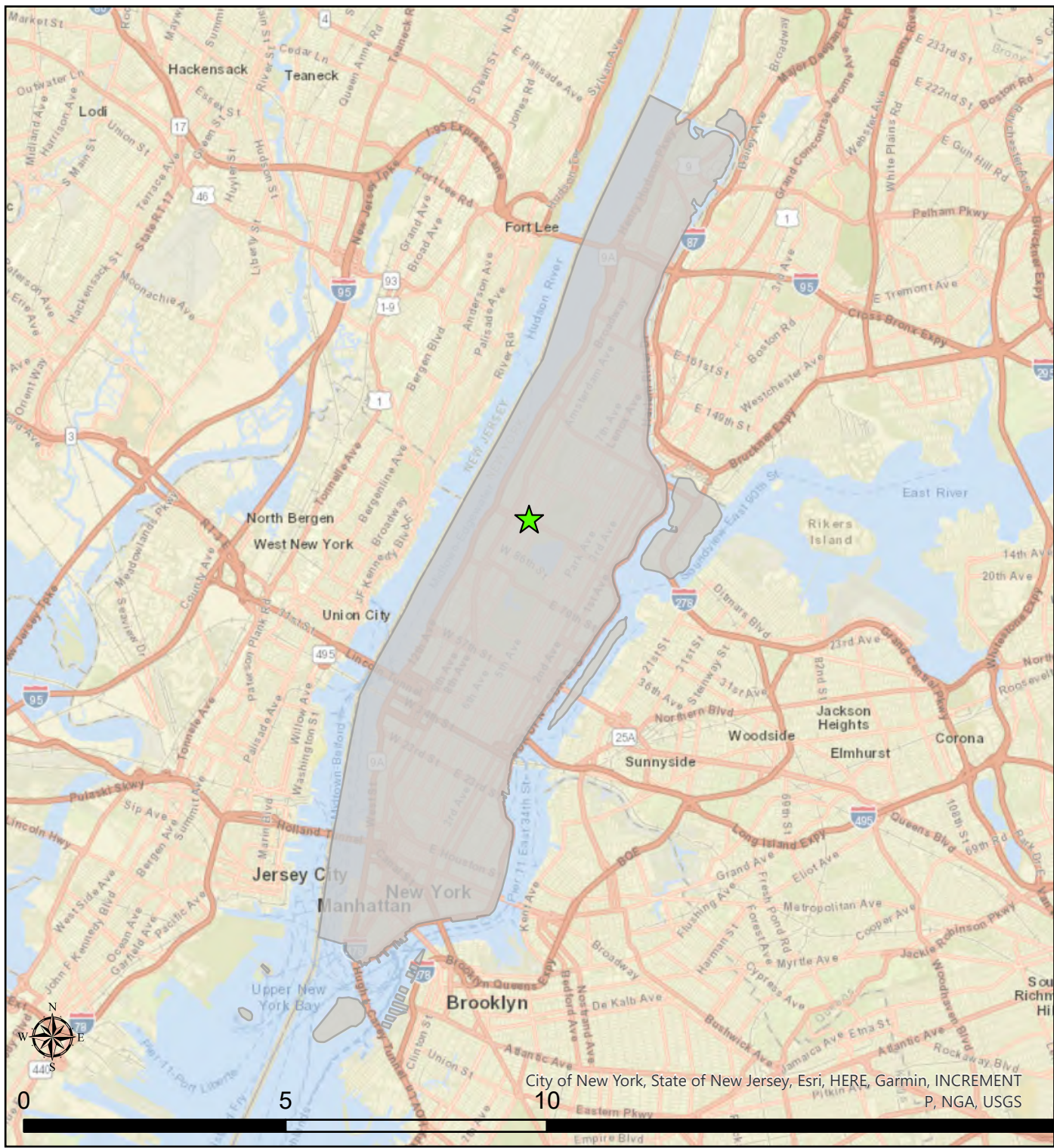

MN-07-120527_A

741 COLUMBUS AVENUE
New York, New York 10025

Spatial Reference
Coordinate System: WGS 1984 Web Mercator Auxiliary Sphere
Projection: Mercator Auxiliary Sphere
Datum: WGS 1984



Source: Selected data from ESRI and EBI.

City of New York, State of New Jersey, Esri, HERE, Garmin, INCREMENT P, NGA, USGS

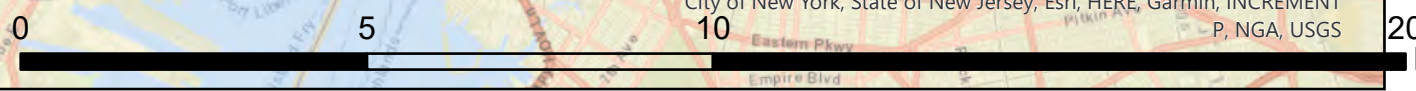



Figure 3: 2022 Google Earth aerial image of the Project Area with project details: power route indicated by the red polygon and fiber route indicated by the green polygon (not to exact scale, for reference only).

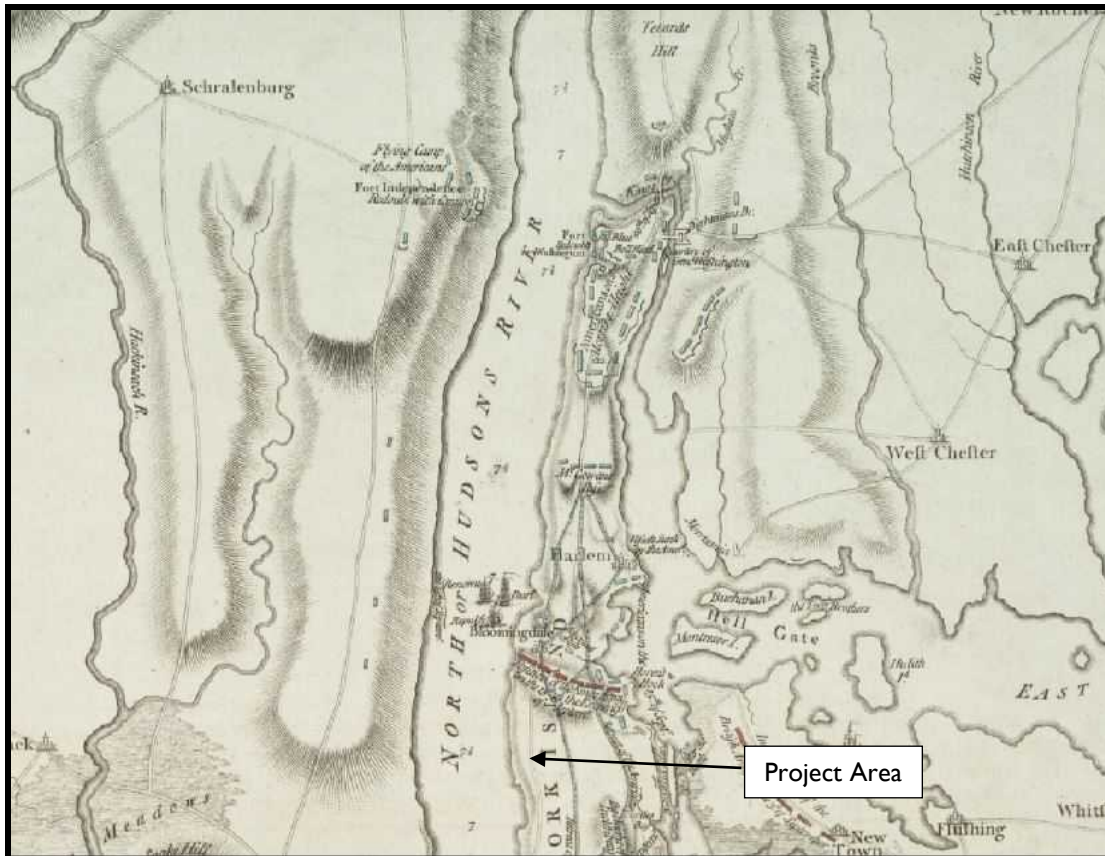

Figure 4: Detail of the 1776 A Plan of New York and Long Island (The New York Public Library 2019a).

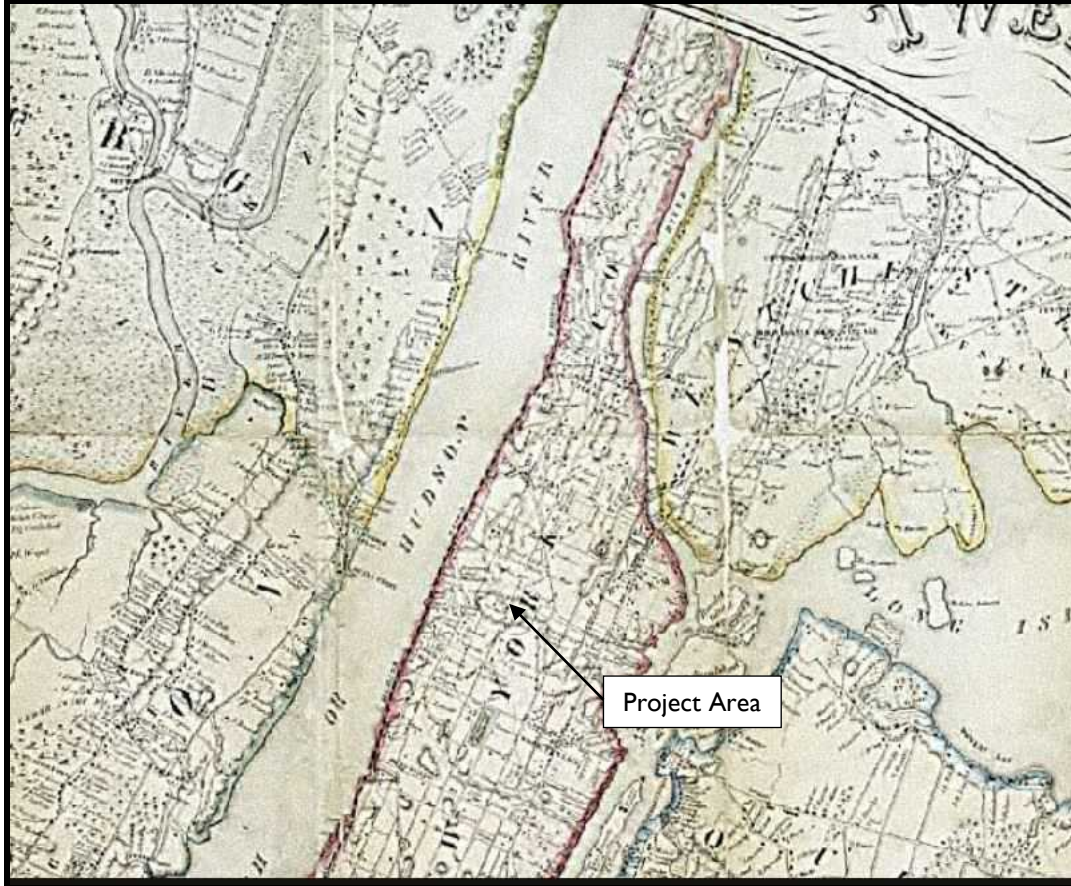

Figure 5: Detail of the 1856 Sidney's map of twelve miles around New-York: with the names of property holders, &c., from entirely new & original surveys The New York Public Library 2019b).



Figure 6: Detail of the 1891 USGS topographic quadrangle with the location of the Project Area (USGS 1891).

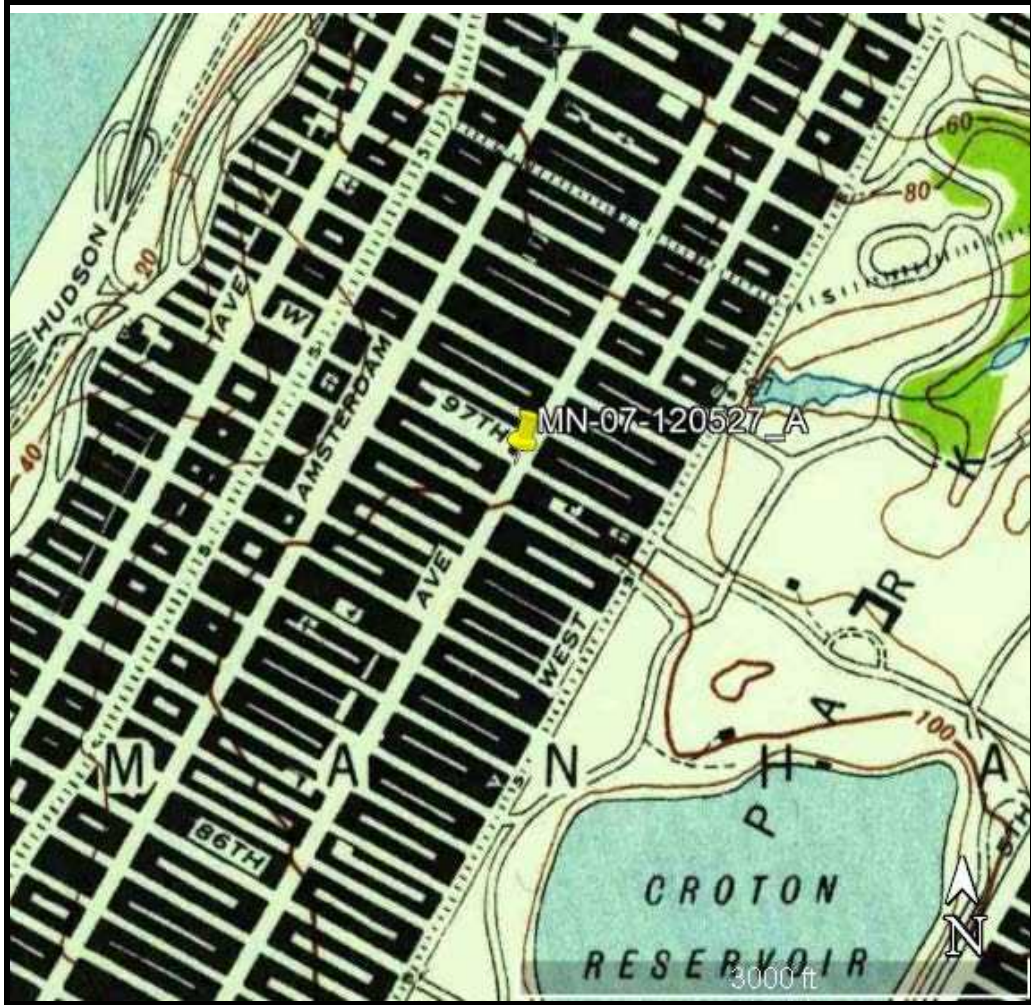

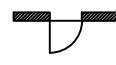



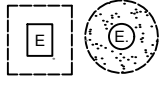

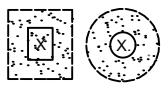







































Figure 7: Detail of the 1947 USGS topographic quadrangle with the location of the Project Area (USGS 1947).

Attachment A: Site Plan

GENERAL NOTES

- | | | | |
|---|---|---|---------------------------------------|
|  | TREE
+5' CLEARANCE |  | BUILDING
ENTRANCE |
|  | TREE PIT
+3' CLEARANCE |  | FIRE CALL BOX
+3' CLEARANCE |
|  | TELECOM MANHOLE
+5' CLEARANCE |  | CATCH BASIN |
|  | ELECTRICAL MANHOLE
+3' CLEARANCE |  | PROPOSED KIOSK
+3' CLEARANCE |
|  | MANHOLE
+3' CLEARANCE |  | CELLAR DOOR |
|  | TRAFFIC LIGHT POLE
+4' CLEARANCE |  | BOLLARD |
|  | SIGN POLE
+3' CLEARANCE |  | EXISTING PAY PHONE
(TO BE REMOVED) |
|  | TRAFFIC SIGN POLE
+3' CLEARANCE |  | TRASH CAN |
|  | BIKE SHARE STATION
+8' CLEARANCE |  | PEDESTRIAN
COUNTDOWN SIGNAL |
|  | BIKE PARKING
+8' CLEARANCE |  | WAYFINDING SYSTEM |
|  | BUS STOP SHELTER
+15' CLEARANCE |  | MEDIA MULTI RACK |
|  | NEWSPAPER KIOSK
+15' CLEARANCE |  | CITY BENCH |
|  | AUTOMATIC PUBLIC TOILET
+15' CLEARANCE |  | ART DISPLAY CASE
+75' CLEARANCE |
|  | UTILITY CABINET
+4' CLEARANCE |  | PARKING METER
+4' CLEARANCE |
|  | PLANTER
+3' CLEARANCE |  | SUBWAY ENTRANCE
+15' CLEARANCE |
|  | FIRE HYDRANT
+15' CLEARANCE |  | SUBWAY GRATING
+3' CLEARANCE |
|  | SIAMESE STANDPIPE
+5' CLEARANCE |  | 10' CORNER
BUILDING CLEARANCE |
|  | MAILBOX
+4' CLEARANCE |  | TRANSFORMER VAULT
+3' CLEARANCE |
|  | PEDESTRIAN POLE
+4' CLEARANCE |  | DIRECTION OF TRAFFIC |
| | |  | DC
DROP CURB |
| | |  | GRANITE |
| | |  | CONCRETE
PAVERS |
| | |  | CONCRETE |
| | |  | BRICK |
| | |  | WATER VALVE
+1' CLEARANCE |
| | |  | GAS VALVE
+1' CLEARANCE |
| | |  | DOT LIGHT POLE
+4' CLEARANCE |

LEGEND



PROJECT NO:	
DRAWN BY:	TM
CHECKED BY:	EV

REV	DATE	DESCRIPTION
0	06/23/22	ISSUED FOR REVIEW

MN-07-120527
741 COLUMBUS AVENUE

LINKNYC PROJECT
DOITT REVIEW

SHEET TITLE
GENERAL NOTES, LEGEND
& ABBREVIATION

SHEET NUMBER
NY-DOITT-NOTES

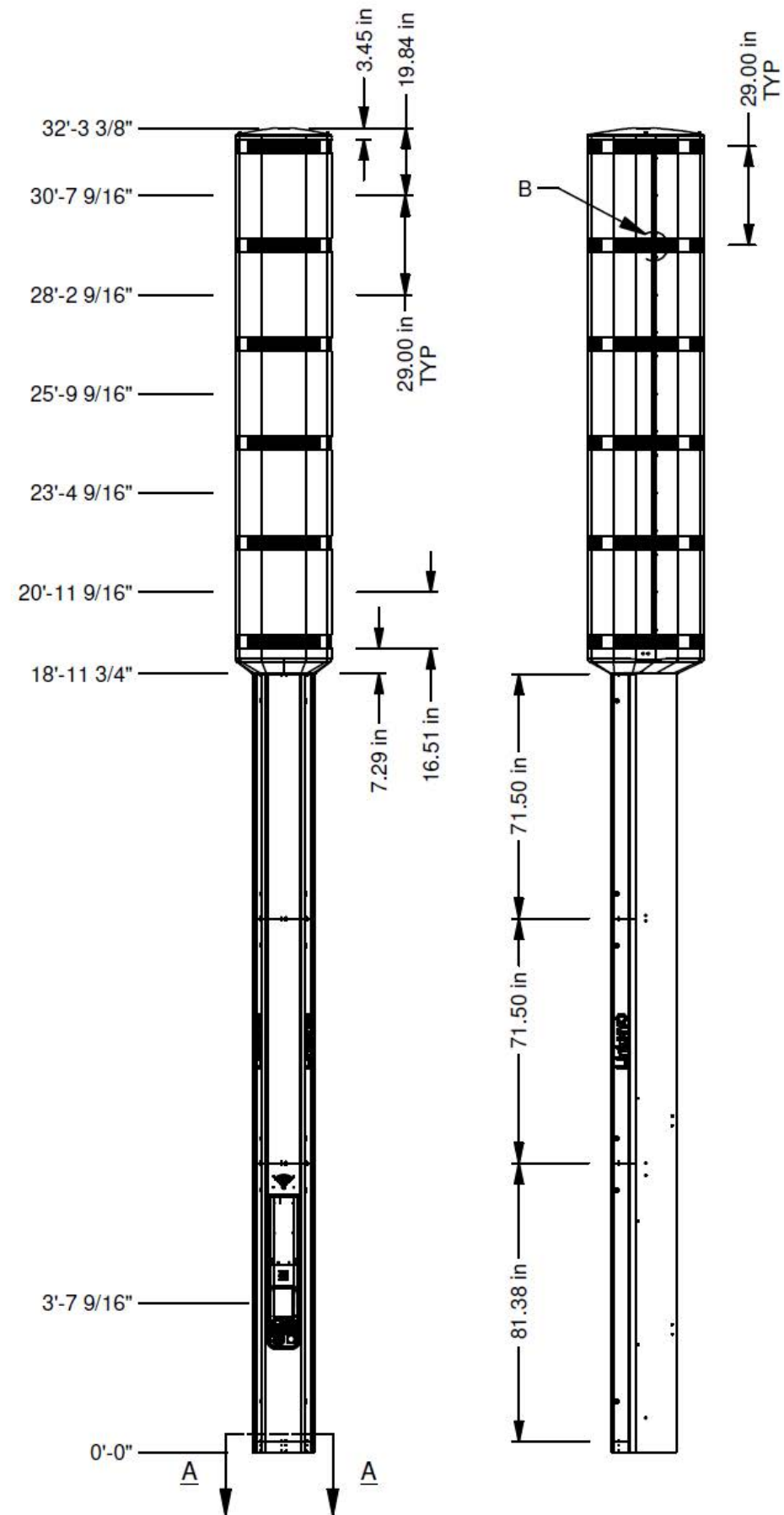

Elevation Drawing

CityBridge

ZenFi
NETWORKS

PROJECT NO: -
DRAWN BY: TM
CHECKED BY: EV

REV	DATE	DESCRIPTION
0	06/24/21	ISSUED FOR REVIEW

MN-07-120527
741 COLUMBUS AVENUE

LINKNYC PROJECT
DOITT REVIEW

Elevation Drawing

SHEET NUMBER
NY-DOITT-NOTES

SHEET 4 OF 5

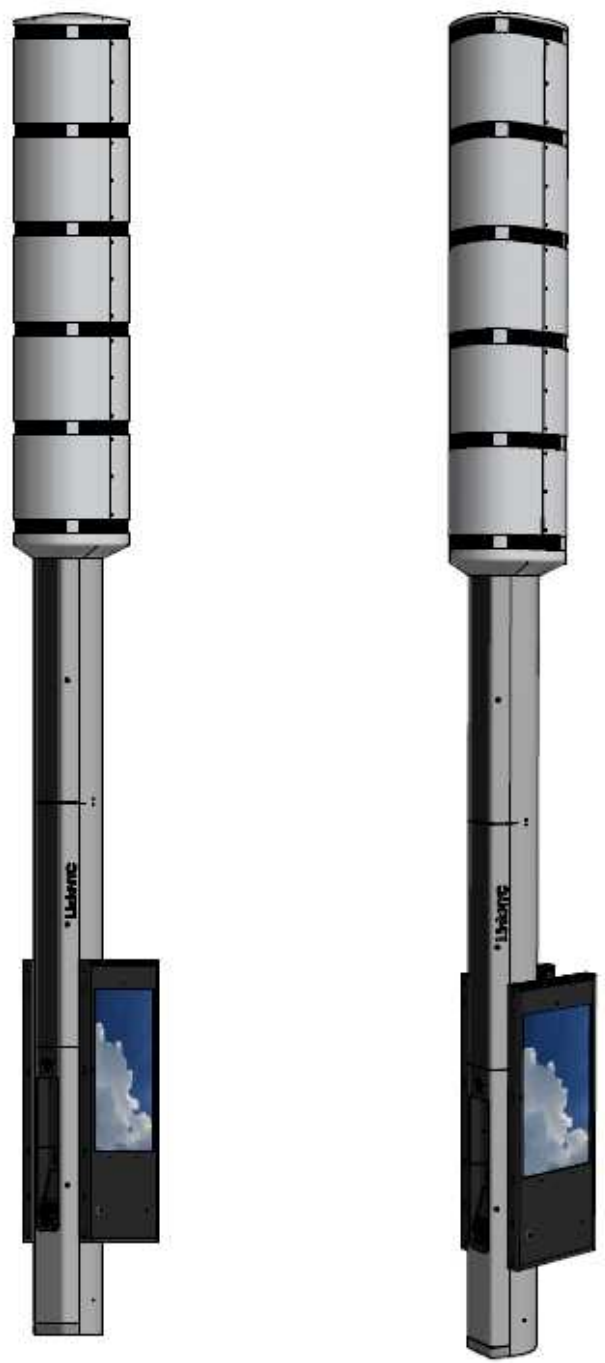
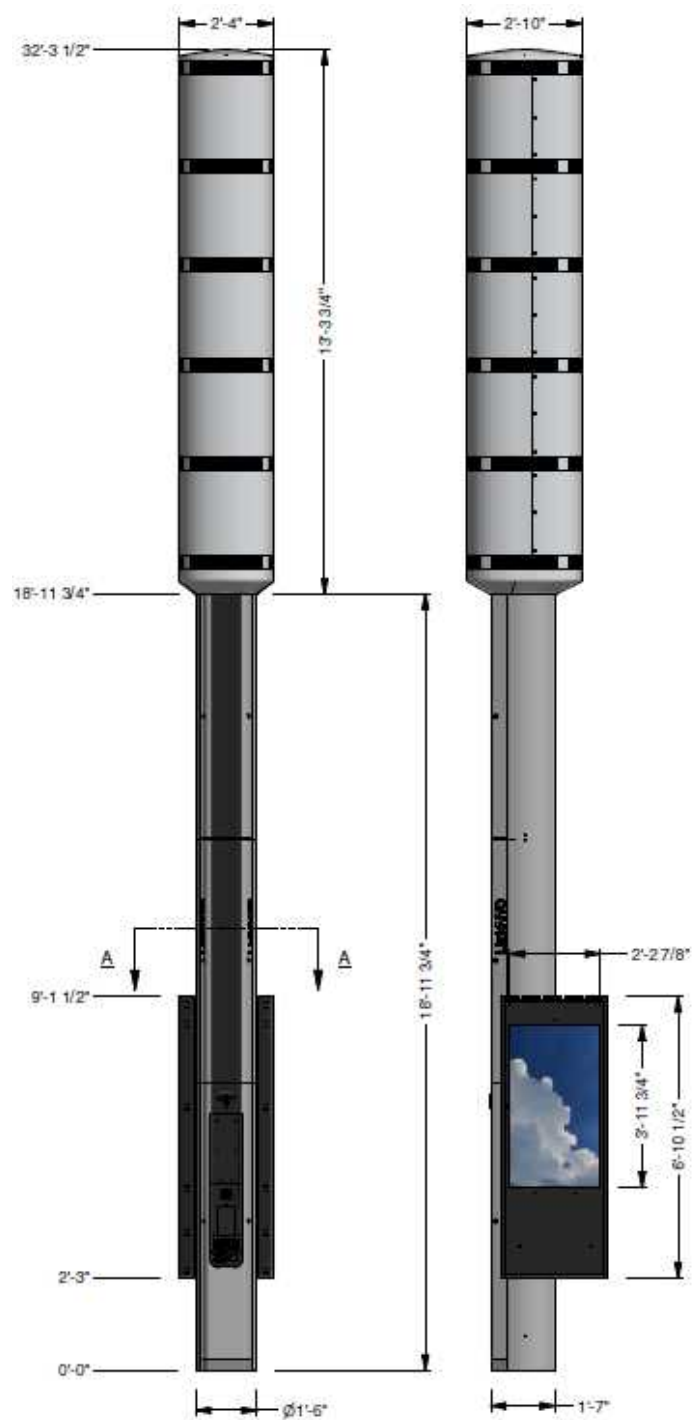

NOTE: ALL DIMENSIONS ARE ±1"

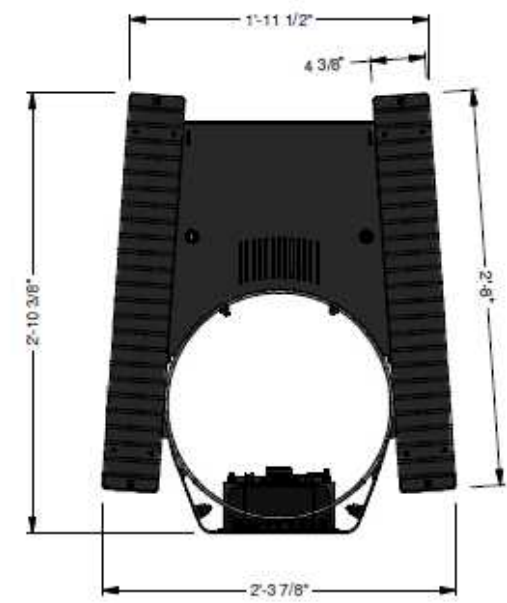

SECTION A-A

LINK NYC
LINK 5G POLE WITH AD DISPLAY

CityBridge

ZenFi
NETWORKS

PROJECT NO: -
DRAWN BY: TM
CHECKED BY: EV

REV	DATE	DESCRIPTION
0	06/24/21	ISSUED FOR REVIEW

MN-07-120527
741 COLUMBUS AVENUE

LINKNYC PROJECT
DOITT REVIEW

Elevation Drawing

SHEET NUMBER
NY-DOITT-NOTES

SHEET 5 OF 6

Elevation Drawing

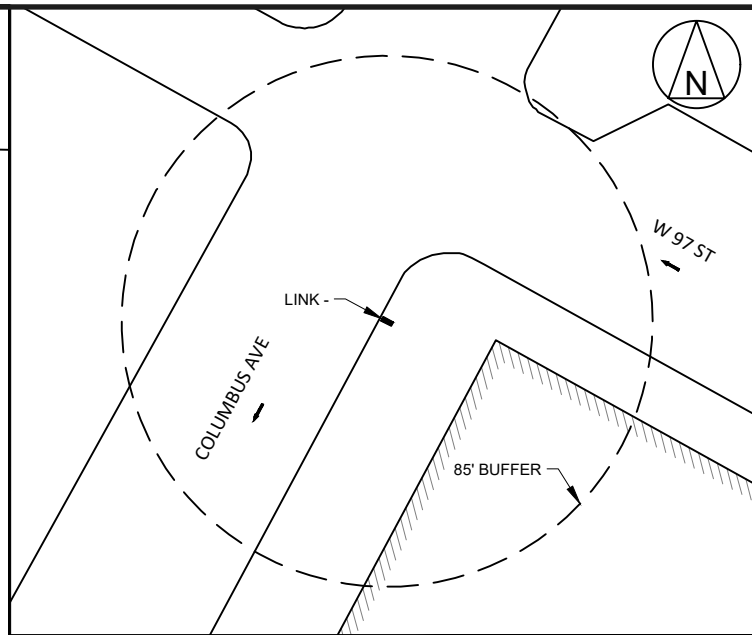
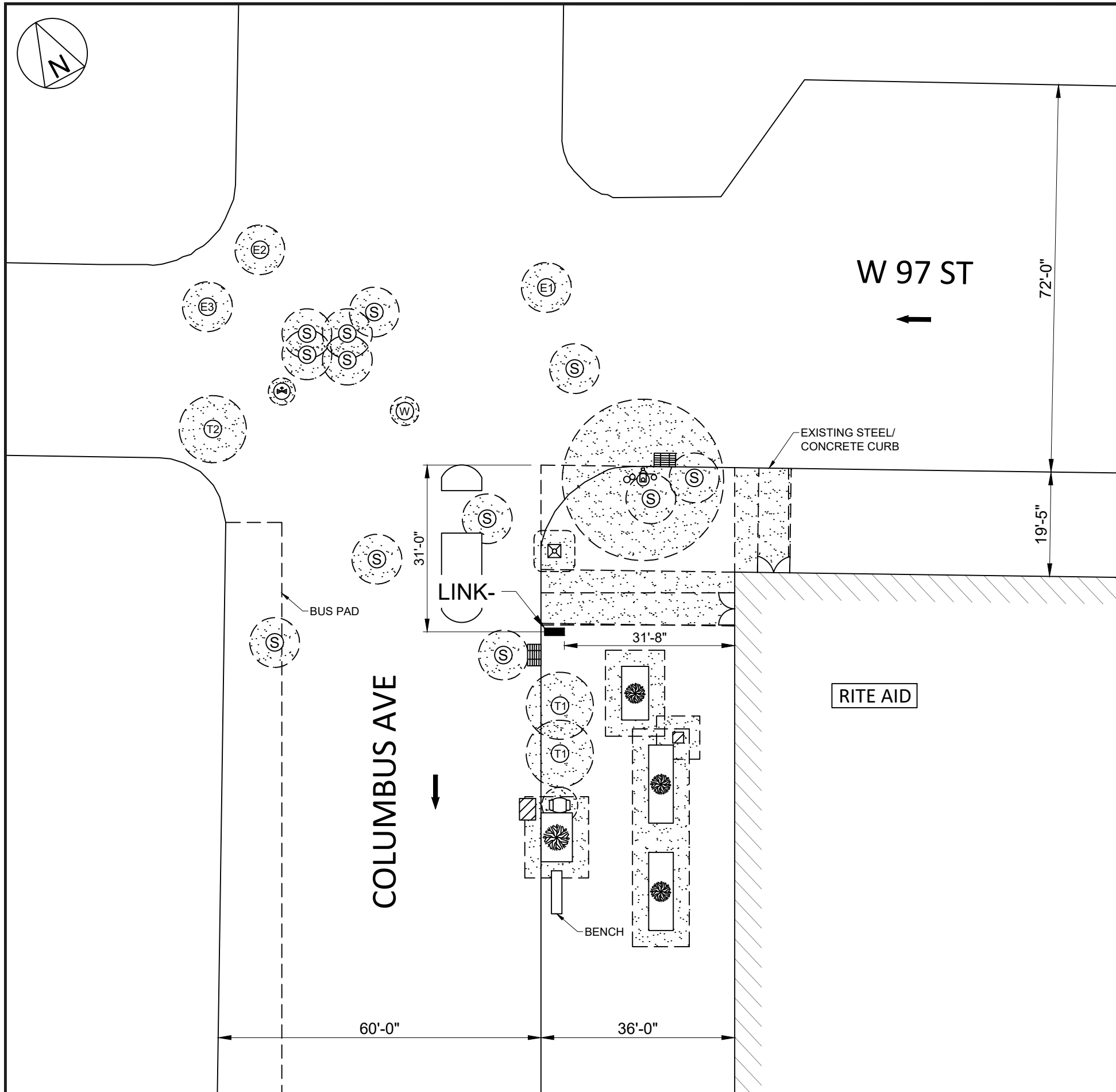

RELATIVE DISTANCES TO THE KIOSK

CITYBRIDGE LINK-

NO.	DESCRIPTION	DISTANCE (Ft.)
1	TO CATCH BASIN	8'-0"
2	TO LIGHT POLE (1)	-
3	TO LIGHT POLE (2)	-
4	TO FIRE HYDRANT	44'-11"
5	TO STREET SIGN (1)	-
6	TO STREET SIGN (2)	-
7	TO MUNI METER	33'-3"
8	TO FIRE PULL BOX	-
9	TO CURB	2'-6"
10	TO BUILDING LINE	31'-8"
11	TO NEAREST SCHOOL	-
12	TO NEAREST CHURCH	-
13	TO TREE	26'-5"
14	TO TREE PIT	23'-11"
15	TO GAS VALVE	95'-4"
16	TO WATER VALVE	68'-10"
17	TO COLUMN	-
18	TO TRAIN ENTRANCE	-
19	TO CLOSEST KIOSK	-
20	TO STREET FURNITURE	-
21	TO SIDEWALK PATH	-
22	TO ENCLOSED CAFE	-
23	TO SIAMESE STANDPIPE	-
24	TO DRIVEWAY	-
25	TO SUBWAY GRATING	-
26	TO BUS STOP SIGN	-
27	TO BENCH	48'-10"
28	TO CANOPY	-
29	TO BIKE RACK	-
30	TO WHEEL CHAIR LIFT	-
31	TO POSTAL BOX	-
32	TO TRANSFORMER	-
33	TO NEAREST RAMP	-



PROJECT NO:
 DRAWN BY: TM
 CHECKED BY: EV

REV	DATE	DESCRIPTION
0	06/23/22	ISSUED FOR REVIEW

MN-07-120527
 741 COLUMBUS AVENUE

LINKNYC PROJECT
 DOITT REVIEW

SHEET TITLE
 ENLARGED SITE PLAN

SHEET NUMBER
 NY-DOITT-
 SHEET 3 OF 4

ENLARGED SITE PLAN

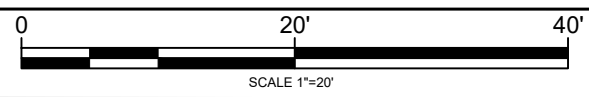

DISTANCE TABLE

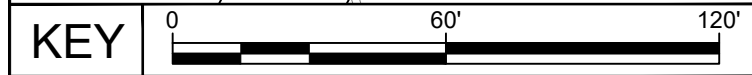
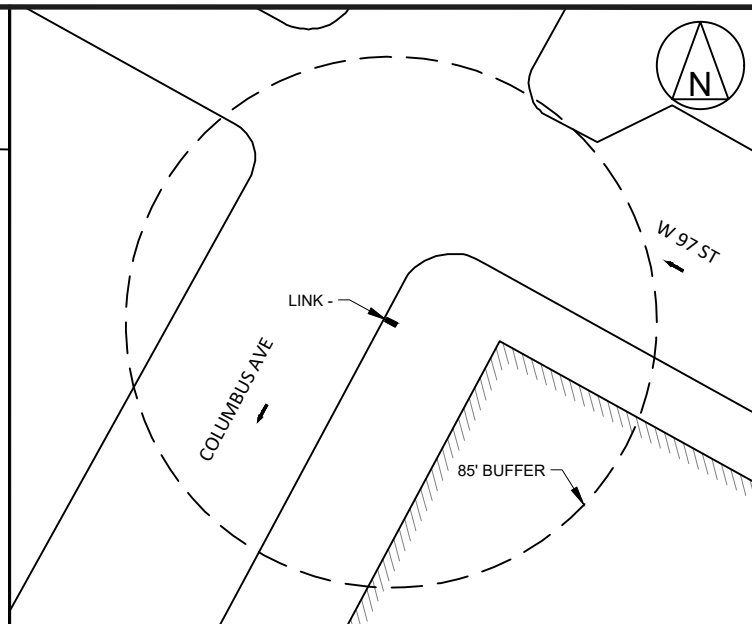
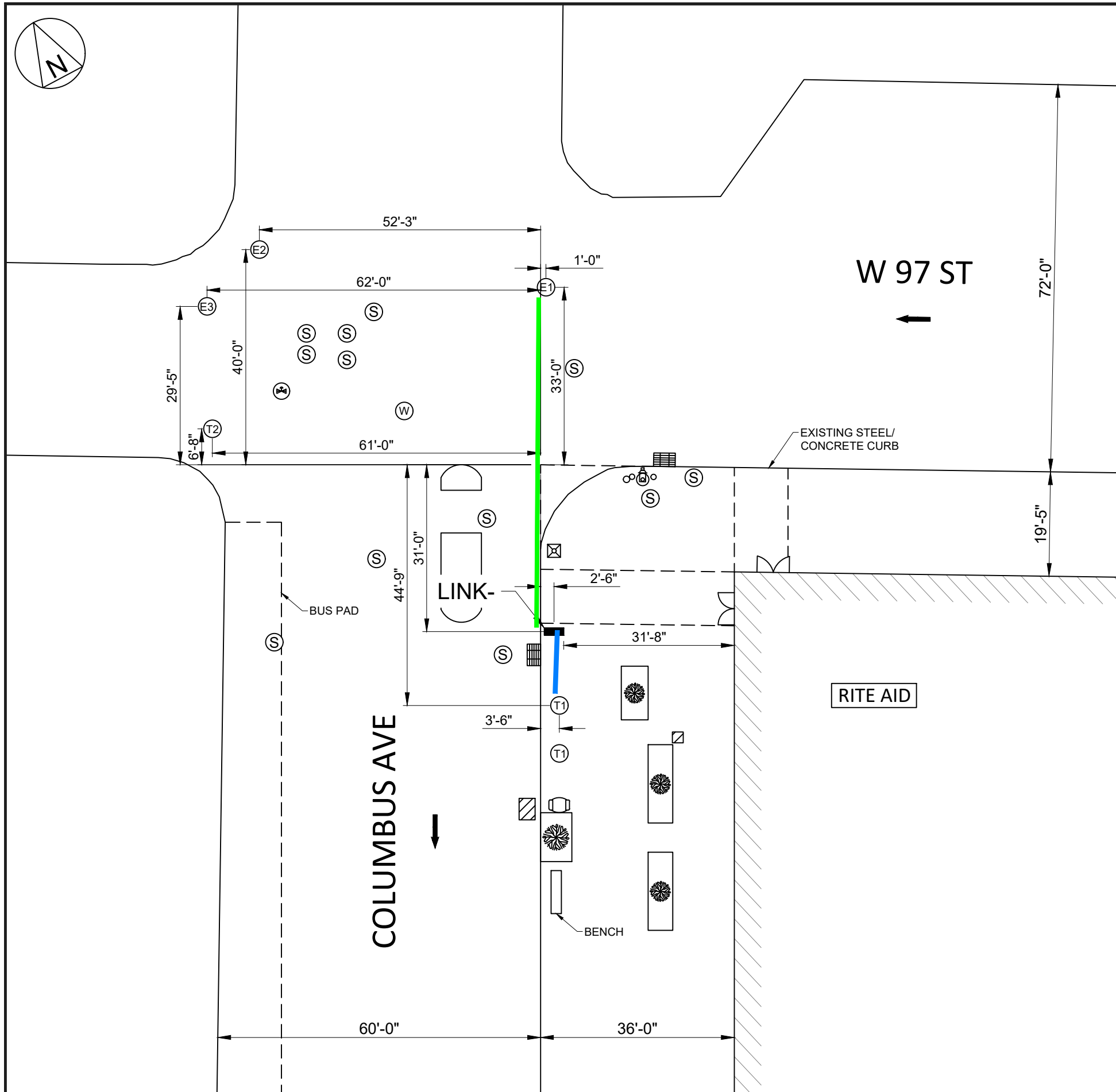

MANHOLE DISTANCES
CITYBRIDGE LINK-

MANHOLE	DESCRIPTION	DISTANCE (FT.)
E1	CON ED MH	65'-6"
E2	CON ED MH	125'-9"
E3	CON ED MH	124'-11"
T1	ECS/VZ MH # 40-178-4	14'-9"
T2	ECS/VZ MH # 40-178-5	101'-2"



PROJECT NO:
DRAWN BY: TM
CHECKED BY: EV

REV	DATE	DESCRIPTION
0	06/23/22	ISSUED FOR REVIEW

MN-07-120527
741 COLUMBUS AVENUE

LINKNYC PROJECT

SHEET TITLE
CONSTRUCTION OVERALL SITE PLAN

SHEET NUMBER
NY--01
SHEET 3 OF 3

CONSTRUCTION OVERALL SITE PLAN

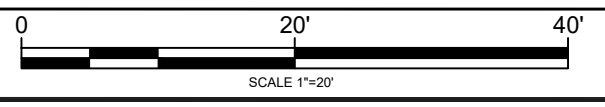

NOTES



LINK - FRONT VIEW



LINK - REAR VIEW



LINK - LEFT VIEW



LINK - RIGHT VIEW



LINK - PANORAMIC VIEW

CityBridge

ZenFi
NETWORKS

PROJECT NO:
DRAWN BY: TM
CHECKED BY: EV

REV	DATE	DESCRIPTION
0	06/23/22	ISSUED FOR REVIEW

MN-07-120527
741 COLUMBUS AVENUE

LINKNYC PROJECT
DOITT REVIEW

SHEET TITLE
EXISTING SITE PHOTOS

SHEET NUMBER

NY-DOITT-

SHEET 4 OF 4

Attachment 8. Historic Properties Visual Effects

Historic Properties Identified for Visual Effects Guidelines

- a. Provide the name and address (including U.S. Postal Service ZIP Code) of each property in the APE for visual effects that is listed in the National Register, has been formally determined eligible for listing by the Keeper of the National Register, or is identified as considered eligible for listing in the records of the SHPO/THPO, pursuant to Section VI.D.1.a. of the Nationwide Agreement.**

On September 18, 2023, EBI Consulting completed a review of the available records as required per Section VI.D.1 of the Federal Communications Commission’s 2004 Nationwide Programmatic Agreement to identify historic properties in the APE for Visual Effects. Please refer to the above list in the FCC Form.

- b. Provide the name and address (including U.S. Postal Service ZIP Code) of each Historic Property in the APE for visual effects, not listed in part “a”, identified through the comments of Indian Tribes, NHOs, local governments, or members of the public. Identify each individual or group whose comments led to the inclusion of a Historic Property in this attachment. For each such property, describe how it satisfies the criteria of eligibility (36 C.F.R. Part 63).**

As of the date of this report, EBI has not received comments from Indian Tribes, NHOs, local governments, or members of the public that identify Historic Properties in the APE for visual effects that are not listed in the above list of Historic Properties.

- c. For any properties listed in the above Historic Properties list, that the Applicant considers no longer eligible for inclusion in the National Register, explain the basis for this recommendation.**

N/A

Applicant’s Name: Boldyn Networks Infrastructure US LLC
 Project Name: MN-07-120527 A
 Project Number: N/A

NT SUBMISSION PACKET -- FCC FORM 620

Approved by OMB
3060-1039
See instructions for
public burden estimates

Attachment 9. Local Government

- a. If any local government has been contacted and invited to become a consulting party pursuant to Section V.A. of the Nationwide Programmatic Agreement, list the local government agencies contacted. Provide a summary of contacts and copies of any relevant documents (e.g., correspondence or notices).**

Please see the attached correspondence with the local government. As of the date of this submission packet, EBI Consulting has not received any comments from the local government. Should a response be received, copies will be forwarded to all consulting parties as an addendum to this submission packet.

- b. If a local government agency will be contacted but has not been to date, explain why and when such contact will take place.**

N/A

Applicant's Name: Boldyn Networks Infrastructure US LLC
Project Name: MN-07-120527 A
Project Number: N/A

October 3, 2023

New York City Landmarks Preservation Commission
Attn: Gina Santucci, Environmental Review Coordinator
1 Centre Street, 9th Floor North
New York, New York 10007
GSantucci@lpc.nyc.gov

Subject: Invitation to Comment – AT – Architectural Review
MN-07-120527_A
Near 741 Columbus Avenue, Manhattan, New York County, New York 10025
EBI Project #6123006709

Dear Gina Santucci:

Pursuant to Section 106 of the National Historic Preservation Act, the regulations promulgated thereunder and interagency agreements developed thereto, EBI Consulting, Inc., on behalf of Boldyn Networks Infrastructure US LLC, provides this notice of a proposed telecommunications facility installation at the address listed above.

EBI would like to inquire if you would be interested in commenting on this proposed project. Please refer to the attached plans for additional details.

EBI is requesting your review of the attached information as part of the Section 106 process only and not as part of the local zoning process. We are only seeking comments related to the proposed project's potential effect to historic properties.

Your comments regarding the proposed project's potential effect on historic properties should be submitted to EBI Consulting, to my attention at 21 B Street, Burlington, MA 01803 or contact me via telephone at the number listed below. Please reference the EBI project number. We would appreciate your comments as soon as possible within the next 30 days. Please do not hesitate to contact me if you have any questions or concerns about the proposed project.

Respectfully Submitted,



Chris Robinson
Architectural Historian II
T (978) 877-3493
crobinson@ebiconsulting.com

Attachment A – Drawings and Maps
Attachment B – Photographs

Sophie Laino

From: Microsoft Outlook <MicrosoftExchange329e71ec88ae4615bbc36ab6ce41109e@ebiconsulting.com>
To: GSantucci@lpc.nyc.gov
Sent: Tuesday, October 3, 2023 2:59 PM
Subject: Relayed: 6123006709 - MN-07-120527_A,Near 741 Columbus Avenue, Manhattan, New York County, New York 10025

Delivery to these recipients or groups is complete, but no delivery notification was sent by the destination server:

GSantucci@lpc.nyc.gov (GSantucci@lpc.nyc.gov)

Subject: 6123006709 - MN-07-120527_A,Near 741 Columbus Avenue, Manhattan, New York County, New York 10025

NT SUBMISSION PACKET -- FCC FORM 620

Approved by OMB
3060-1039
See instructions for
public burden estimates

Attachment 10. Other Consulting Parties and Public Notice

List additional consulting parties that were invited to participate by the Applicant, or independently requested to participate. Provide any relevant correspondence or other documents.

Please see the attached correspondence with interested parties. As of the date of this submission packet, EBI Consulting has not received any comments from any interested parties. Should a response be received, copies will be forwarded to all consulting parties as an addendum to this submission packet.

You are required to provide a Public Notice Attachment.

Attached, please find a copy of the legal notice regarding the proposed telecommunications installation that was posted in *New York Post* on October 12, 2023. As of the date of this submission packet, no comments regarding this notice have been received by EBI. Should a response be received, copies will be forwarded to all consulting parties as an addendum to this submission packet.

Applicant's Name: Boldyn Networks Infrastructure US LLC
Project Name: MN-07-120527 A
Project Number: N/A

October 3, 2023

Frampton Tolbert, Historic Districts Council framptont@hdc.org

Andrea Goldwyn & Peg Breen, New York Landmark Conservancy
andregoldwyn@nylandmarks.org
pegbreen@nylandmarks.org

Janna Rudler, Preservation League of New York State jrudler@preservenys.org

Elizabeth Goldstein, Municipal Art Society egoldstein@mas.org

Sean Khorsandi, LandmarkWest! seankhorsandi@landmarkwest.org

Subject: **Initial Courtesy Notification – No Review Clock**
MN-07-120527_A
Near 741 Columbus Avenue, Manhattan, New York County, New York 10025
EBI Project #6123006709

To Whom It May Concern:

Your organization has requested consulting party status in the Section 106 consultation process for Link NYC 5G towers in your area of interest. On behalf of Boldyn Networks Infrastructure US LLC; we are providing initial information on a proposed facility at the above-referenced location to allow you additional time to review the proposed site if you wish. Per the Federal Communications Commission's guidance in Section V.G of their 2004 Nationwide Programmatic Agreement, as a consulting party, you are entitled to:

- (1) receive notices, copies of submission packets, correspondence and other documents provided to the SHPO/THPO in a Section 106 review; and
- (2) be provided an opportunity to have [your] views expressed and taken into account by the Applicant, the SHPO/THPO and, where appropriate, by the Commission.

EBI would like to inquire if you would be interested in commenting on this proposed project and any adverse effects you believe it will have on historic properties. Please refer to the attached maps, project plans and list of historic properties and local landmarks we have already identified during the State Historic Preservation Office records search. **Please note that this is an initial courtesy notification, the 30-day review period for Consulting Party comments does NOT commence with this correspondence. You will receive the full submission packet as prescribed by the FCC in the coming weeks.** We simply share this initial notification so that if you know of any immediate concerns, we may review those concerns and begin attempts to address them.

If you have any comments regarding the above-referenced project's potential effect on historic properties please submit those comments to EBI Consulting, to my attention via email at CityBridgeLink5g@ebiconsulting.com or via US mail at 21 B Street, Burlington, MA 01803. Please reference the EBI project number in the subject line above. Please do not hesitate to contact me if you have any questions or concerns about the proposed project.

Respectfully Submitted,



Chris Robinson
Architectural Historian II
(781) 418-2314
citybridgelink5g@ebiconsulting.com

Attachments – New York State Historic Preservation Office, Historic Resources Map and List
New York City Landmarks Preservation Commission Map and List
Street Map
Topographic Map
Project Plans

New York State Historic Preservation Office, Historic Resources Map



New York State Historic Preservation Office, Historic Resources List

USNNum (NY SHPO #) or National Register #	Historic Resource Name	Street Address	Status
06101.011537	The Baldwin Flats	46-48 West 96 th Street, Manhattan, New York, New York 10025	NR-Eligible
06101.011536	Apt Bldg (Non-Contributing)	44 West 96 th Street, Manhattan, New York, New York 10025	NR-Eligible
06101.011535	Rowhouse (5 OF 5)	42 West 96 th Street, Manhattan, New York, New York 10025	NR-Eligible

New York City Landmarks Preservation Commission Map



New York City Landmarks Preservation Commission, Landmarks List

LPC #	LPC Name	Street Address
LP-1647	Upper West Side/Central Park West Historic District	Manhattan, New York, New York 10025

Sophie Laino

From: Microsoft Outlook <MicrosoftExchange329e71ec88ae4615bbc36ab6ce41109e@ebiconsulting.com>
To: Frampton Tolbert; andreagoldwyn@nylandmarks.org; pegbreen@nylandmarks.org;
jrudler@preservenys.org; Elizabeth Goldstein; seankhorsandi@landmarkwest.org
Sent: Tuesday, October 3, 2023 3:17 PM
Subject: Relayed: MN-07-120527_A / COURTESY NOTIFICATION / 741 Columbus Avenue, Manhattan, New York County, New York / EBI # 6123006709

Delivery to these recipients or groups is complete, but no delivery notification was sent by the destination server:

[Frampton Tolbert \(framptont@hdc.org\)](mailto:framptont@hdc.org)

[andreagoldwyn@nylandmarks.org \(andreagoldwyn@nylandmarks.org\)](mailto:andreagoldwyn@nylandmarks.org)

[pegbreen@nylandmarks.org \(pegbreen@nylandmarks.org\)](mailto:pegbreen@nylandmarks.org)

[jrudler@preservenys.org \(jrudler@preservenys.org\)](mailto:jrudler@preservenys.org)

[Elizabeth Goldstein \(egoldstein@mas.org\)](mailto:egoldstein@mas.org)

[seankhorsandi@landmarkwest.org \(seankhorsandi@landmarkwest.org\)](mailto:seankhorsandi@landmarkwest.org)

Subject: MN-07-120527_A / COURTESY NOTIFICATION / 741 Columbus Avenue, Manhattan, New York County, New York / EBI # 6123006709

Classifieds

nypost.com

EMPLOYMENT

GENERAL HELP WANTED

NEED EXTRA MONEY TO PAY FOR BILLS? VACATION? SAVINGS?



Part Time - Early AM | Easy and Fun! Newspaper Delivery Drivers Wanted

Be your own boss! Deliver newspapers close to home for just a couple of hours each day and make over \$1000.00 monthly... plus bonus... Really!

- Just a few hours each morning
- 7 days (or less) ... done by 6am!
- Must have a reliable vehicle

Start making \$\$\$ tonight! Routes available near where you live!!!

BROOKLYN, BRONX, QUEENS

To Apply - Text: "PCFCASH"

617-207-6350 or Call 1-800-515-8000

Walk-ins Welcome 2 am - 4 am

909 Essex St., Brooklyn NY 11208

4220 Vireo Ave, Bronx NY 10470

48-02 31st Place Long Island City NY 11101



PROFESSIONAL

Lead Data Scientist, IBM Corporation, New York, NY (Up to 40% telecommuting permitted): Lead the effort to characterize business problems into quantifiable framework. Ensure alignment with project leads, product managers, stakeholders, executives, end-users, and junior Data Scientists. Plan for others, set project vision and timeline, scope and ensure adequate resources. Manage work of other junior team members and actively provide guidance and coaching. Contribute to creation of IP in the form of patents, publications, assets, and external presentations. Assess, identify, and address knowledge gap of oneself and junior Data Scientists. Promote recent advances in related Machine Learning (ML) algorithms. Serve as subject matter expert (SME) of ML knowledge and a variety of data sources within the team. Lead the effort on data querying, interpretation, visualization, feature engineering, model selection, training, validation and improvement. Advise project leads, stakeholders and executives on related data science topics. Set vision on infrastructure within the project and ensure smooth operations. Utilize Python, SQL, Machine Learning and Statistical Modeling, Continuous Integration and Continuous Deployment, Github, Pytest, RedHat OpenShift, Cloud Software. Required: Master's degree or equivalent in Statistics, Mathematics, Computer Science, Engineering, Data Science, or related (employer will accept a Bachelor's degree plus five (5) years of progressive experience in lieu of a Master's degree) and one (1) year of experience as a Data Scientist or related. One (1) year of experience must include utilizing Python, SQL, Machine Learning and Statistical Modeling, Continuous Integration and Continuous Deployment, Github, Pytest, RedHat OpenShift, Cloud Software, \$165,000-\$214,300.00 per year. Please send resumes to recruited@us.ibm.com. Applicants must reference M267 in the subject line.

NOTICES

LEGAL NOTICES

NOTICE OF FORMATION OF A LIMITED LIABILITY COMPANY

Notice of Formation of Vpm Master LLC. Articles of Organization filed with Secretary of State of NY (SSNY) on 2023-08-30. Office location: Orange County, SSNY designated as agent of Limited Liability Company (LLC) upon whom process against it may be served. SSNY should mail process to Marco Scalia : 27 Pinehurst Cir Monroe NY 10950. Purpose: Any lawful purpose

NOTICE OF FORMATION OF A LIMITED LIABILITY COMPANY

Notice of Formation of The Loaf, LLC. Articles of Organization filed with Secretary of State of NY (SSNY) on 2023-09-27. Office location: Orange County, SSNY designated as agent of Limited Liability Company (LLC) upon whom process against it may be served. SSNY should mail process to Kristina Baumann: 1365 Kings Hwy P.O. Box 536 Sugar Loaf NY 10981. Purpose: Any lawful purpose

Looking For A New Career?

Check Out Your Options in the **NEW YORK POST** Career Training Listings

NOTICES

LEGAL NOTICES

NOTICE OF SALE OF COOPERATIVE UNIT SECURITY BY VIRTUE OF A DEFAULT

PLEASE TAKE NOTICE: By virtue of a default under a Security Agreement dated April 14, 2016, executed by Michael J. Maynard ("Debtor"), in favor of JPMorgan Chase Bank, N.A. ("Secured Party"), said Secured Party, by Auctioneer(s): John William O'Keefe, Terence Gee, or Stephan G. Marcellin, will conduct a public sale of the security consisting of 3,000 shares of stock of the lessor, 520 East 72nd Owners Corp. ("Corporation"), and all right, title, and interest in and to a Proprietary Lease between said Corporation and Debtor for the unit known as **520 East 72nd Street, Units 1 C/D, New York, New York 10021**, together with all fixtures and articles of personal property now or hereafter affixed to or used in connection with said units on **October 25, 2023 at 1:45 PM**, at the Portico of the New York County Courthouse, 60 Centre Street, New York, New York 10007 in satisfaction of an indebtedness in the unpaid principal amount of \$906,516.18, plus interest, late fees, attorney fees, maintenance in arrears, and all other advanced charges summarized below:

Principal Balance: \$906,516.18

COVID Relief Deferred Interest:

From April 1, 2020 – June 30, 2020: \$9,119.34

From August 1, 2020 – October 31, 2020: \$9,062.74

Interest:

From October 1, 2021 – September 1, 2023: \$168,401.77

Late Fees: \$250.00

Appraisal Fees: \$3,350.00

Environmental Inspection Fee: \$2,200.00

Title Search Fee: \$300.00

Legal Fees and Costs: \$18,052.30 (as of August 31, 2023)

TOTAL DUE AS OF THE DATE OF THIS NOTICE: \$1,119,252.33

In addition, you are responsible for all costs and disbursements permitted by law. Contact this firm for exact figures before remitting a certified check for the amount due.

Further, if Debtor or any person(s) has a dispute as to the validity of the lien or amount claimed herein, it may be sought to proceeding under Lien Law, Section 201-a, within 10 days of the service of this notice.

You are entitled to an accounting of the unpaid indebtedness secured by the property that we intend to sell. You may request an accounting by calling us at (212) 596-7037

The unit is sold "AS IS" AND POSSESSION IS TO BE OBTAINED BY THE PURCHASER.

Said sale is subject to payment of all sums due, if any, to the Corporation (which, as of September 1, 2023, were \$60,345.77), and the consent if necessary, of said Corporation; any existing tenancy; payment of all expenses and fees of the secured party with respect thereto; terms of sale and auctioneer's fees; flip-tax; State, City, and County transfer tax. The Secured Party reserves the right to bid on the security interest, to set the minimum sale amount and to reject any and all bids. The Secured Party makes no warranties or representations. Each bidder must make his/her own inquiry regarding the unit and any liens or debts in connection therewith.

The sale is subject to the Terms of Sale, including: tender of a ten (10%) percent deposit in an official bank or certified check made payable to **Parker Ibrahim & Berg LLP** at the auction; balance due upon closing within thirty (30) days; the payment of all sums due to the Corporation, and; and any existing tenancy.

ATTORNEYS FOR SECURED PARTY:

Parker Ibrahim & Berg LLP

5 Penn Plaza, Suite 2371

New York, New York 10001

Telephone: (212) 596-7037

Facsimile: (212) 596-7036

NOTICE OF SALE OF COOPERATIVE APARTMENT SECURITY BY VIRTUE OF A DEFAULT

BY VIRTUE OF DEFAULT in a security agreement filed on May 4, 1999, with indebtedness due by August 1, 2023, by MICHAEL B. AROUH in accordance with its rights as holder of the security, JPMORGAN CHASE BANK, NATIONAL ASSOCIATION, by its successors and/or assignees, by Richard J. Cantwell, John William O'Keefe, Terence Gee or Stephan G. Marcellin, auctioneer(s), will conduct a public sale of the security consisting of One Hundred and Ten (110) shares of stock issued by 408 West 57th Owners Corp., and all right title and interest in and to a proprietary lease in a building known as and by the street address **408 West 57th Street, Apartment 5J, New York, NY 10019**, with an estimated value of \$767,000.00, together with fixtures and articles of personal property now or hereafter affixed to or used in connection with said apartment on **October 25, 2023, at 1:15PM**, at the Portico of the NEW YORK Courthouse, 60 Centre Street, New York, NY 10007, in satisfaction of an indebtedness in the original principal amount of \$68,000.00, on which there remains an unpaid principal balance of \$48,285.09 plus interest from December 1, 2011, subject to open maintenance charges.

Notice is hereby being given to MICHAEL B. AROUH that payment of the debt is due in full by **OCTOBER 2, 2023**. Further, that if MICHAEL B. AROUH or any person(s) has a dispute of validity of the lien or amount claimed herein, it may be sought to proceeding under Lien Law, Section 201-a, within 10 days of the service of this notice.

You are entitled to an accounting of the unpaid indebtedness secured by the property that we intend to sell. You may request an accounting by calling us at (585) 232-7400 Ext. 312.

The secured party reserves the right to bid on the security interest, to set the minimum sale amount and to reject any and all bids. The secured party makes no warranties or representations. Each bidder must make his/her own inquiry regarding the apartment and any liens or debts in connection therewith. The sale is subject to the Terms of Sale, including ten (10%) percent deposit by certified funds at the auction; balance due upon closing within thirty (30) days; the payment of all sums due to the cooperative corporation; and any existing tenancy.

Certified funds are to be made payable ONLY to Fein, Such & Crane, LLP.

The apartment will be sold AS IS, possession is to be obtained by purchaser(s).

Dated: September 22, 2023

FEIN, SUCH & CRANE, LLP
ATTORNEYS FOR SECURED CREDITOR,
JPMORGAN CHASE BANK,
NATIONAL ASSOCIATION
28 East Main Street, Suite 1800
Rochester, NY 14614 (585) 232-7400

NOTICE OF SALE

SUPREME COURT
COUNTY OF QUEENS

Deutsche Bank National Trust Company, as Trustee for RB5GC Mortgage Loan Trust, Mortgage Loan Pass-Through Certificates, Series 2007-B, Plaintiff
AGAINST

Santos Serrano; Alina Serrano; et al.,
Defendant(s)

Pursuant to a Judgment of Foreclosure and Sale duly entered February 19, 2019 in the undersigned Referee will sell at public auction at the steps of Queens County Supreme Court, 88-11 Sutphin Boulevard, Jamaica, NY 11435 on October 27, 2023 at 10:15AM, premises known as 38-16 100th Street, Flushing a/k/a Corona, NY 11368. All that certain plot piece or parcel of land, with the buildings and improvements erected, situate, lying and being in the Borough and County of Queens, City and State of New York, Block: 1765 Lot: 7. Approximate amount of judgment \$496,875.26 plus interest and costs. Premises will be sold subject to provisions of filed Judgment. Index# 708193/2015. The auction will be conducted pursuant to the COVID-19 Policies Concerning Public Auctions of Foreclosed Property established by the Eleventh Judicial District.

Joseph N. Armao, Esq., Referee

LOGS Legal Group LLP f/k/a Shapiro, DiCaro & Barak, LLC Attorney(s) for the Plaintiff
175 Mile Crossing Boulevard
Rochester, New York 14624
(877) 430-4792

Dated: July 31, 2023

Boldyn Networks Infrastructure US LLC is proposing to construct a 32.5ft metal pole telecommunications tower facility located in the vicinity of 741 Columbus Avenue, Manhattan, New York County, NY (40 47 36.1644 N; 73 58 1.2426 W). Any interested party wishing to submit comments regarding the potential effects the proposed facility may have on any historic property may do so by sending comments to: Project 6123006599, EBI Consulting, 21 B St. Burlington, MA 01803, email to citybridgelink5g@ebiconsulting.com or by calling (781) 418-2314.

Boldyn Networks Infrastructure US LLC is proposing to construct a 32.5ft metal pole telecommunications tower facility located in the vicinity of 20 Beard Street, Brooklyn, Kings County, NY (40 40 21.8 N; 74 0 43.25 W). Any interested party wishing to submit comments regarding the potential effects the proposed facility may have on any historic property may do so by sending comments to: Project 6123006599, EBI Consulting, 21 B St. Burlington, MA 01803, email to citybridgelink5g@ebiconsulting.com or by calling (781) 418-2314.

Want it sold?

Sell it in the
NEW YORK POST
Classifieds
Email cloyd@nypost.com



CAREERS

CAREER TRAINING

BUSINESS OPPORTUNITIES

FINANCIAL SERVICES

REAL ESTATE SERVICES

MERCHANDISE FOR SALE

PETS

AUTOMOTIVE

LEGAL & PUBLIC NOTICE

PLACE AN AD

Email:
cloyd@nypost.com

DEADLINES

Monday: Friday 2:30PM
Mon @Work: Friday 2:30PM
Tuesday: Monday 2:30PM
Wednesday: Tuesday 2:30PM
Thursday: Wednesday 2:30PM
Friday: Thursday 2:30PM
Saturday: Friday 2:30PM
Sunday: Friday 2:30PM

PAYMENTS

We Accept
Visa, Mastercard,
American Express,
checks and money orders

The New York Post reserves the right to edit, reclassify, reject or cancel an ad at any time. We can only give appropriate credit, not to exceed the cost of the ad, for one insertion. We are not liable for complete omissions. Any discrepancies must be brought to our attention within 30 days of the first day the ad runs, in order to receive consideration for credit.

MERCHANDISE

COLLECTIBLES

BUYING BASEBALL CARDS
And All Other Sports Cards,
Cert. Memorabilia & Graded
Vintage Cards. Prefer Pre-1980
Paying Top Dollar \$\$\$
small or large collections
Call Henry 917-273-2353

NOTICES

LEGAL NOTICES

Boldyn Networks Infrastructure US LLC is proposing to construct a 32.5ft metal pole telecommunications tower facility located in the vicinity of 1070.5th Avenue, Manhattan, New York County, NY (40 46 58.33N; 73 57 34.43W). Any interested party wishing to submit comments regarding the potential effects the proposed facility may have on any historic property may do so by sending comments to: Project 6123006714, EBI Consulting, 21 B St. Burlington, MA 01803, email to citybridgelink5g@ebiconsulting.com or by calling (781) 418-2314.

Classifieds

nypost.com

NOTICES

LEGAL NOTICES

NOTICE OF PUBLIC SALE CO-OP APARTMENT

PLEASE TAKE NOTICE, that pursuant to Article 9 of the Uniform Commercial Code, STEPHAN G. MARCELIN, Auctioneer, JOHN WILLIAM O'KEEFE, Auctioneer, or TERENCE GEL, Auctioneer will sell at public auction with reserve to the highest bidder, New York County Courthouse, 60 Centre St. New York, New York 10007, at 1:45 PM on October 18, 2023, security consisting of 167 shares of ROYAL YORK OWNERS CORPORATION, in the name of ROBERT MALONE, and all right, title and interest in and to a Proprietary Lease for Cooperative, located in a building known as and by the street address 425 EAST 63RD STREET, #W2G, NEW YORK NY 10021, between ROBERT MALONE as Lessee, and ROYAL YORK OWNERS CORPORATION, as Lessor.

This sale is held to satisfy an indebtedness of the unpaid principal balance, interest, attorney fees and advances through October 18, 2023, and to enforce the rights of SPECIALIZED LOAN SERVICING LLC (the "Secured Party"), arising under a Security Agreement dated November 5, 1997, executed by and between ROBERT MALONE and THE CHASE MANHATTAN BANK The Secured Party reserves the right to bid.

The Co-op Apartment will be sold "AS IS", subject to open common charges, and possession is to be obtained by the purchaser.

DATED: September 15, 2023

Knuckles, Komosinski & Manfro, LLP Attorneys for SECURED PARTY, 565 Taxter Row Suite 590 Elmsford, NY 10523 (914) 345-3020

Legal Notices published in all NYS counties.



Place your notice in NYP Classifieds.

Email Karen at kinscho@nypost.com

NEW YORK POST

PET PLACE

DOGS

PORTUGUESE WATER DOG PUPPIES AKC Breeder of Merit APP written @ Doceukenet.com Written Health Guarantee! Call (716) 435-9922



MALTESE PUPPIES Adorable males and females, toy or teacup sizes, shots and papers. Call 718-306-4136



POMERANIAN PUPPIES Adorable males and females, toy or teacup sizes, shots and papers. Call 718-306-4136



YORKIE PUPPIES ADORABLE, pure bred, toy & teacup sizes. Call 718-306-4136

NFL Injury Report

THURSDAY BRONCOS AT CHIEFS

DENVER
Out: DT D.J. Jones (knee), LB Baron Browning (knee), LB Frank Clark (illness). **Questionable:** TE Greg Dulcich (hamstring). **Full:** C Lloyd Cushenberry (quadricep), NT Mike Purcell (ribs), FS Justin Simmons (hip), RB Javonte Williams (quadricep), LB Justin Strnad (back).

KANSAS CITY
Questionable: TE Travis Kelce (ankle), DE George Karlaftis (hamstring), P Tommy Townsend (left knee). **Full:** LB Nick Bolton (ankle), DT Matt Dickerson (knee), DE Michael Danna (rib), CB Trent McDuffie (quadricep), CB L'Jarius Sneed (knee), WR Kadarius Toney (toe), LB Drue Tranter (ankle).

SUNDAY GIANTS AT BILLS

GIANTS
DNP: QB Daniel Jones (neck), LB Micah McFadden (ankle), DE Azeez Ojulari (ankle), WR Wan'Dale Robinson (knee), C John Michael Schmitz (shoulder), OT Andrew Thomas (hamstring), TE Darren Waller (groin). **Limited:** CB Deonte Banks (ankle), RB Saquon Barkley (ankle), RB Gary Brightwell (ankle), CB Cordale Flott (ankle), G Shane Lemieux (groin), G Marcus McKethan (knee).

BUFFALO
DNP: CB Dane Jackson (foot). **Limited:** TE Dalton Kincaid (concussion), TE Dawson Knox (wrist), DE Greg Rousseau (foot). **Full:** CB Christian Benford (shoulder), LB Baylon Spector (hamstring).

EAGLES AT JETS

PHILADELPHIA
DNP: S Justin Evans (knee), CB Darius Slay (knee), DT Marlon Tuipulotu (triceps). **Limited:** S Sydney Brown (hamstring), DT Fletcher Cox (back), LB Nakobe Dean (foot), TE Jack Stoll (shoulder). **Full:** RB Rashaad Penny (illness).

JETS
DNP: FB Nick Bowden (calf), CB Brandin Echols (hamstring), CB Justin Hardee (hamstring). **Limited:** T Mekhi Becton (knee), CB D.J. Reed (concussion), T Billy Turner (toe). **Full:** DE Micheal Clemons (ankle), C Joe Tippmann (knee).

CARDINALS AT RAMS

ARIZONA
DNP: WR Marquise Brown (illness), TE Elijah Higgins (illness), S Jalen Thompson (hamstring). **Limited:** RB Keaontay Ingram (neck), DL Jonathan Ledbetter (finger), CB Garrett Williams (knee). **Full:** OL Kelvin Beachum (hand), OL Dennis Daley (ankle).

L.A. RAMS
DNP: G Kevin Dotson (ankle), LB Ernest Jones (knee), DT Larrell Murchinson (knee), OL Joe Noteboom (groin), LB Christian Rozeboom (high). **Limited:** WR Ben Skowronek (achilles).

RAVENS VS. TITANS (IN LONDON, ENGLAND)

BALTIMORE
OLB Jadeveon Clowney (illness), LB Odafe Oweh (ankle), S Geno Stone (hamstring). **Limited:** WR Odell Beckham Jr. (ankle), CB Marlon Humphrey (foot), OT Patrick Mekari (illness/chest), OT Morgan Moses (shoulder). **Full:** RB Keaton Mitchell (shoulder).

TENNESSEE
DNP: WR Treyton Burks (knee), LB Luke Gifford (hamstring), CB Elijah Molden (hamstring), DT Jeffery Simmons (shoulder), DT Teair Tart (toe). **Limited:** LB Azeez Al-Shaair (neck), C Aaron Brewer (neck), RB Derrick Henry (NIR-resting player), WR DeAndre Hopkins (NIR-resting player).

PANTHERS AT DOLPHINS

CAROLINA
DNP: OLB Justin Houston (NIR-resting player), RB Miles Sanders (shoulder),

FS Xavier Woods (hamstring), G Chandler Zavala (neck), WR Adam Thielen (NIR-resting player).

Limited: OT Taylor Moton (knee), G Calvin Throckmorton (calf) G Austin Corbett (knee), TE Stephen Sullivan (hip), LB Brian Burns (ankle), DT Derrick Brown (knee/ankle). **Full:** CB Donte Jackson (shoulder).

MIAMI

DNP: CB Xavien Howard (NIR-resting player), FB Alec Ingold (foot), OL Connor Williams (groin). **Limited:** WR Braxton Berrios (knee), WR Tyreek Hill (NIR-resting player), G Robert Jones (knee), RB Raheem Mostert (NIR-resting player), DB Nik Needham (achilles), LB Jaelan Phillips (oblique), RB Jeff Wilson (ribs/finger).

LIONS AT BUCCANEERS

DETROIT
DNP: CB Brian Branch (ankle), RB Jahmyr Gibbs (hamstring), G Jonah Jackson (ankle), RB Bam Knight (shoulder), TE James Mitchell (hamstring), RB Emmanuel Moseley (knee). **Limited:** OT Taylor Decker (ankle), WR Amon-Ra St. Brown (abdomen). **Full:** DB Khalil Dorsey (illness), C Frank Ragnow (NIR-resting player/toe).

TAMPA BAY

DNP: WR Mike Evans (hamstring). **Limited:** OT Luke Goedeke (calf). **Full:** DB Jamal Dean (neck/shoulder), LB SirVocea Dennis (hamstring), DT Calijah Kancey (calf), FS Ryan Neal (concussion), LB Anthony Nelson (concussion), CB Derrek Pitts (hamstring), LB Devin White (foot).

COLTS AT JAGUARS

INDIANAPOLIS
DNP: TE Mo'Alie-Cox (concussion), T Braden Smith (foot/wrist). **Full:** LB Shaquille Leonard (groin), DE Kwity Paye (concussion), T Bernard Raimann (concussion).

JACKSONVILLE

DNP: WR Zay Jones (knee), OT Walker Little (knee). **Limited:** CB Christian Braswell (hamstring), LB Devin Lloyd (thumb). **Full:** OT Cam Robinson (elbow), LB Dawuane Smoot (achilles).

VIKINGS AT BEARS

MINNESOTA
Limited: WR Jordan Addison (ankle), LB Marcus Davenport (elbow), CB Akayleb Evans (knee). **Full:** S Lewis Cine (hamstring), RB Kene Nwangwu (back).

CHICAGO

DNP: RB Khalil Herbert (ankle), RB Travis Homer (hamstring), OL Lucas Patrick (concussion), RB Roschon Johnson (concussion), WR Equanimeous St. Brown (hamstring). **Limited:** DB Kyle Gordon (hand), DB Eddie Jackson (foot), TE Cole Kmet (hamstring), DB Jaylon Johnson (hamstring), CB Terrell Smith (ankle).

PATRIOTS AT RAIDERS

NEW ENGLAND
DNP: WR Demario Douglas (concussion), LB Matthew Judon (elbow), WR Juju Smith-Schuster (concussion). **Limited:** DL Christian Bamore (knee), OT Trent Brown (chest), DB Cody Davis (knee), DL Trey Flowers (foot), DL Davon Godchaux (ankle), CB Jonathan Jones (ankle), OL Mike Onwenu (ankle), OL Riley Reiff (knee), G Cole Strange (knee), LB Josh Uche (knee), CB Shaun Wade (shoulder).

LAS VEGAS

DNP: WR Davante Adams (shoulder), CB Nate Hobbs (ankle). **Limited:** CB Jakorian Bennett (shoulder), DE Maxx Crosby (knee), S Marcus Epps (knee), CB David Long Jr. (ankle), WR Jakobi Meyers (wrist), WR Tre

Tucker (knee). **Full:** DE Malcolm Koonce (knee), CB Amik Robertson (knee).

SAINTS AT TEXANS

NEW ORLEANS

DNP: S J.T. Gray (hamstring), TE Juwan Johnson (calf), CB Lonnie Johnson (hamstring), FB Adam Prentice (knee), T Landon Young (hip). **Limited:** TE Jimmy Graham (NIR-resting player), T James Hurst (foot), DE Cameron Jordan (back), WR Chris Olave (toe), T Ryan Ramczyk (NIR-resting player). **Full:** QB Derek Carr (right shoulder), S Marcus Maye (NIR-return from suspension).

HOUSTON

DNP: WR Tank Dell (concussion), DT Maliek Collins (abdomen), CB Shaquill Griffin (calf), OT Laremy Tunsil (knee), WR Robert Woods (wrist), OT George Fant (hip/shoulder), LB Christian Harris (concussion), G Shaq Mason (ankle). **Full:** WR Noah Brown (groin), OT Tytus Howard (hand), OT Josh Jones (hand), MLB Denzel Perryman (hand/wrist), CB Tavierre Thomas (hand).

49ERS AT BROWNS

SAN FRANCISCO
DNP: LB Dre Greenlaw (NIR-rest), TE George Kittle (NIR-rest), RB Elijah Mitchell (knee), OT Trent Williams (NIR-rest). **Limited:** OL Aaron Banks (shoulder).

CLEVELAND

DNP: OL Joel Bitonio (knee), WR Amari Cooper (NIR-rest), DE Myles Garrett (foot), TE David Njoku (face, hand), QB Deshaun Watson (right shoulder). **Limited:** RB Jerome Ford (knee), OL Ethan Pocic (chest, knee, foot).

SEAHAWKS AT BENGALS

SEATTLE

DNP: CB Coby Bryant (toe), CB Artie Burns (hamstring), OL Damien Lewis (ankle), WR DK Metcalf (ribs). **Limited:** S Jamal Adams (concussion), LB Jordyn Brooks (knee), OT Charles Cross (toe), OL Phil Haynes (calf). **Full:** DE Dre'Mont Jones (ankle), NT Jarran Reed (shin), QB Geno Smith (knee).

CINCINNATI

DNP: CB Chidobe Awuzie (back), LB Akeem Davis-Gaither (knee), LB Devin Harper (hamstring). **Limited:** WR Tee Higgins (ribs).

COMMANDERS AT FALCONS

WASHINGTON

DNP: TE Curtis Hodges (illness), CB Christian Holmes (hamstring). **Full:** T Charles Leno (finger), DE Efe Obada (knee), WR Curtis Samuel (finger).

ATLANTA

DNP: DE Calais Campbell (NIR-resting player). **Limited:** LB Bud Dupree (wrist), T Kaleb McGary (knee), TE Jonnu Smith (ankle).

NBA Preseason

Wednesday

Boston 112, Philadelphia 101
L.A. Lakers 109, Sacramento 101

Thursday

Maccabi Ra'anana at Nets, 7:30pm
Charlotte at Washington, 7pm
Oklahoma City vs Detroit, 7pm, Montreal Orlando at Cleveland, 7pm
Memphis at Atlanta, 7:30pm
Denver at Chicago, 8pm
New Orleans vs Houston, 8pm, Birmingham, Ala.
Phoenix at Portland, 10pm

WNBA Playoffs

Finals: Best-of-five x-if necessary New York Liberty vs. Las Vegas Aces
Las Vegas leads series, 2-0
Game 1: Aces 99, Liberty 82
Game 2: Aces 104, Liberty 76
Sun., Oct. 15: Aces at Liberty, 3pm
x-Game 4: Oct. 18: Aces at Liberty, 8pm
x-Game 5: Oct. 20: Liberty at Aces, 9pm

NFL

AMERICAN CONFERENCE

East	W	L	T	Pct.	PF	PA
Miami	4	1	0	.800	181	135
Buffalo	3	2	0	.600	159	80
Jets	2	3	0	.400	93	105
New England	1	4	0	.200	55	131

South	W	L	T	Pct.	PF	PA
Indianapolis	3	2	0	.600	120	115
Jacksonville	3	2	0	.600	105	102
Houston	2	3	0	.400	115	100
Tennessee	2	3	0	.400	88	93

North	W	L	T	Pct.	PF	PA
Baltimore	3	2	0	.600	109	75
Pittsburgh	3	2	0	.600	79	110
Cleveland	2	2	0	.500	76	60
Cincinnati	2	3	0	.400	83	114

West	W	L	T	Pct.	PF	PA
Kansas City	4	1	0	.800	128	80
L.A. Chargers	2	3	0	.400	110	104
Las Vegas	2	3	0	.400	79	114
Denver	1	4	0	.200	121	181

NATIONAL CONFERENCE

East	W	L	T	Pct.	PF	PA
Philadelphia	5	0	0	1.000	141	104
Dallas	3	2	0	.600	134	83
Washington	2	3	0	.400	109	160
Giants	1	4	0	.200	62	153

South	W	L	T	Pct.	PF	PA
Tampa Bay	3	1	0	.750	84	68
Atlanta	3	2	0	.600	83	96
New Orleans	3	2	0	.600	96	76
Carolina	0	5	0	.000	91	144

North	W	L	T	Pct.	PF	PA
Detroit	4	1	0	.800	148	107
Green Bay	2	3	0	.400	113	113
Chicago	1	4	0	.200	115	157
Minnesota	1	4	0	.200	110	122

West	W	L	T	Pct.	PF	PA
San Francisco	5	0	0	1.000	167	68
Seattle	3	1	0	.750	111	91
L.A. Rams	2	3	0	.400	112	108
Arizona	1	4	0	.200	108	136

Thursday

Denver at Kansas City, 8:15pm

Sunday

Philadelphia at Jets, 4:25pm

Giants at Buffalo, 8:20pm

Baltimore vs Tennessee at London, GB, 9:30 a.m.

Carolina at Miami, 1pm

Indianapolis at Jacksonville, 1pm

Minnesota at Chicago, 1pm

New Orleans at Houston, 1pm

San Francisco at Cleveland, 1pm

Seattle at Cincinnati, 1pm

Washington at Atlanta, 1pm

New England at Las Vegas, 4:05pm

Arizona at L.A. Rams, 4:25pm

Detroit at Tampa Bay, 4:25pm

Bye: Pittsburgh, Green Bay

Monday

Dallas at L.A. Chargers, 8:15pm

College Football

South

UTEP 27, Florida International 14

Southwest

New Mexico St. 27, Sam Houston St. 13

Tennis

WTA Zhengzhou Open

At Zhongyuan Tennis Training Base Management Center; Zhengzhou, China;
Purse: \$780,637; Surface: Hardcourt outdoor;(seedings in parentheses);
Women's Singles - Round of 16
Anhelina Kalinina, Ukraine, def. Vera Zvonareva, Russia, 7-5, 6-1.
Jasmine Paolini, Italy, def. Caroline Garcia (6), France, 3-6, 6-4, 7-5.
Zheng Qinwen, China, def. Maria Sakkari (3), Greece, 7-6 (2), 6-3.
Lesia Tsurenko, Ukraine, def. Donna Vekic (10), Croatia, 7-6 (4), 7-6 (2).

NT SUBMISSION PACKET -- FCC FORM 620

Approved by OMB
3060-1039
See instructions for
public burden estimates

Attachment II. SHPO Specific Forms

Please see attached required SHPO form.

Applicant's Name: Boldyn Networks Infrastructure US LLC
Project Name: MN-07-120527 A
Project Number: N/A

The Historic Preservation Review Process in New York State

In order to insure that historic preservation is carefully considered in publicly-funded or permitted undertakings*, there are laws at each level of government that require projects to be reviewed for their potential impact/effect on historic properties. At the federal level, Section 106 of the National Historic Preservation Act of 1966 (NHPA) directs the review of federally funded, licensed or permitted projects. At the state level, Section 14.09 of the New York State Parks, Recreation and Historic Preservation Law of 1980 performs a comparable function. Local environmental review for municipalities is carried out under the State Environmental Quality Review Act (SEQRA) of 1978.

regulations on line at:

<http://nysparks.state.ny.us> then select **HISTORIC PRESERVATION** then select **Environmental Review**

Project review is conducted in two stages. First, the Field Services Bureau assesses affected properties to determine whether or not they are listed or eligible for listing in the New York State or National Registers of Historic Places. If so, it is deemed "historic" and worthy of protection and the second stage of review is undertaken. The project is reviewed to evaluate its impact on the properties significant materials and character. Where adverse effects are identified, alternatives are explored to avoid, or reduce project impacts; where this is unsuccessful, mitigation measures are developed and formal agreement documents are prepared stipulating these measures.

ALL PROJECTS SUBMITTED FOR REVIEW SHOULD INCLUDE THE FOLLOWING MATERIAL(S).

Project Description

Attach a full description of the nature and extent of the work to be undertaken as part of this project. Relevant portions of the project applications or environmental statements may be submitted.

Maps Locating Project

Include a map locating the project in the community. The map must clearly show street and road names surrounding the project area as well as the location of all portions of the project. Appropriate maps include tax maps, Sanborn Insurance maps, and/or USGS quadrangle maps.

Photographs

Photographs may be black and white prints, color prints, or color laser/photo copies; standard (black and white) photocopies are NOT acceptable.

-If the project involves rehabilitation, include photographs of the building(s) involved. Label each exterior view to a site map and label all interior views.

-If the project involves new construction, include photographs of the surrounding area looking out from the project site. Include photographs of any buildings (more than 50 years old) that are located on the project property or on adjoining property.

NOTE: Projects submissions will not be accepted via facsimile or e-mail.

***Undertaking** is defined as an agency's purchase, lease or sale of a property, assistance through grants, loans or guarantees, issuing of licenses, permits or approvals, and work performed pursuant to delegation or mandate.